

TECHNICAL MANUAL

**OPERATOR'S AND ORGANIZATIONAL MAINTENANCE MANUAL
INCLUDING REPAIR PARTS AND SPECIAL TOOLS LISTS**

SIMULATOR, RADIO FREQUENCY SM-442A/GRC

This copy is a reprint which includes current pages from Changes 1 and 2. The title was changed by C1 to read as shown above.

WARNING

Voltages up to 200 volts dc and 115 volts ac exist in this equipment. Serious injury may result if operating personnel fail to observe safety precautions.

DON'T TAKE CHANCES!

Operation and maintenance personnel should be familiar with the requirements of TB SIG 291 before attempting installation or operation of Simulator, Radio Frequency SM-442A/GRC.

CAUTION

Be sure to make resistance measurements in the transistorized circuits of this equipment only as specified; the voltage present in the ohmmeter may destroy transistors.

TECHNICAL MANUAL }
 No. 11-6625-847-12

HEADQUARTERS
 DEPARTMENT OF THE ARMY
 WASHINGTON, D.C., 30 August 1967

**Operator's and Organizational Maintenance Manual
 Including Repair Parts and Special Tools List
 SIMULATOR, RADIO FREQUENCY SM-442A/GRC**

		<i>Paragraph</i>	<i>Page</i>
CHAPTER	1. INTRODUCTION		
Section	I. General	1-1—1-3	1-1
	II. Description and data.....	1-4—1-7	1-1
CHAPTER	2. INSTALLATION.....	2-1—2-5	2-1
CHAPTER	3. OPERATING INSTRUCTIONS		
Section	I. Operating controls, indicators, and connectors.....	3-1—3-7	3-1
	II. Operational instructions.....	3-8—3-19	3-21
CHAPTER	4. OPERATOR AND ORGANIZATIONAL MAINTENANCE		
Section	I. Operator's maintenance.....	4-1—4-5	4-1
	II. Organizational maintenance	4-6—4-12	4-2
	III. Organizational troubleshooting	4-13—4-26	4-3
CHAPTER	5. SHIPMENT, LIMITED STORAGE, AND DEMOLITION TO PREVENT ENEMY USE		
Section	I. Shipment and limited storage	5-1—5-5	5-1
	II. Demolition of materiel to prevent enemy use.....	5-6—5-7	5-1
APPENDIX	A. REFERENCES.....		A-1
	B. BASIC ISSUE ITEMS LIST (Deleted)		
	C. MAINTENANCE ALLOCATION		C-1
	D. ORGANIZATIONAL MAINTENANCE REPAIR PARTS.....		D-1
Index		I-1

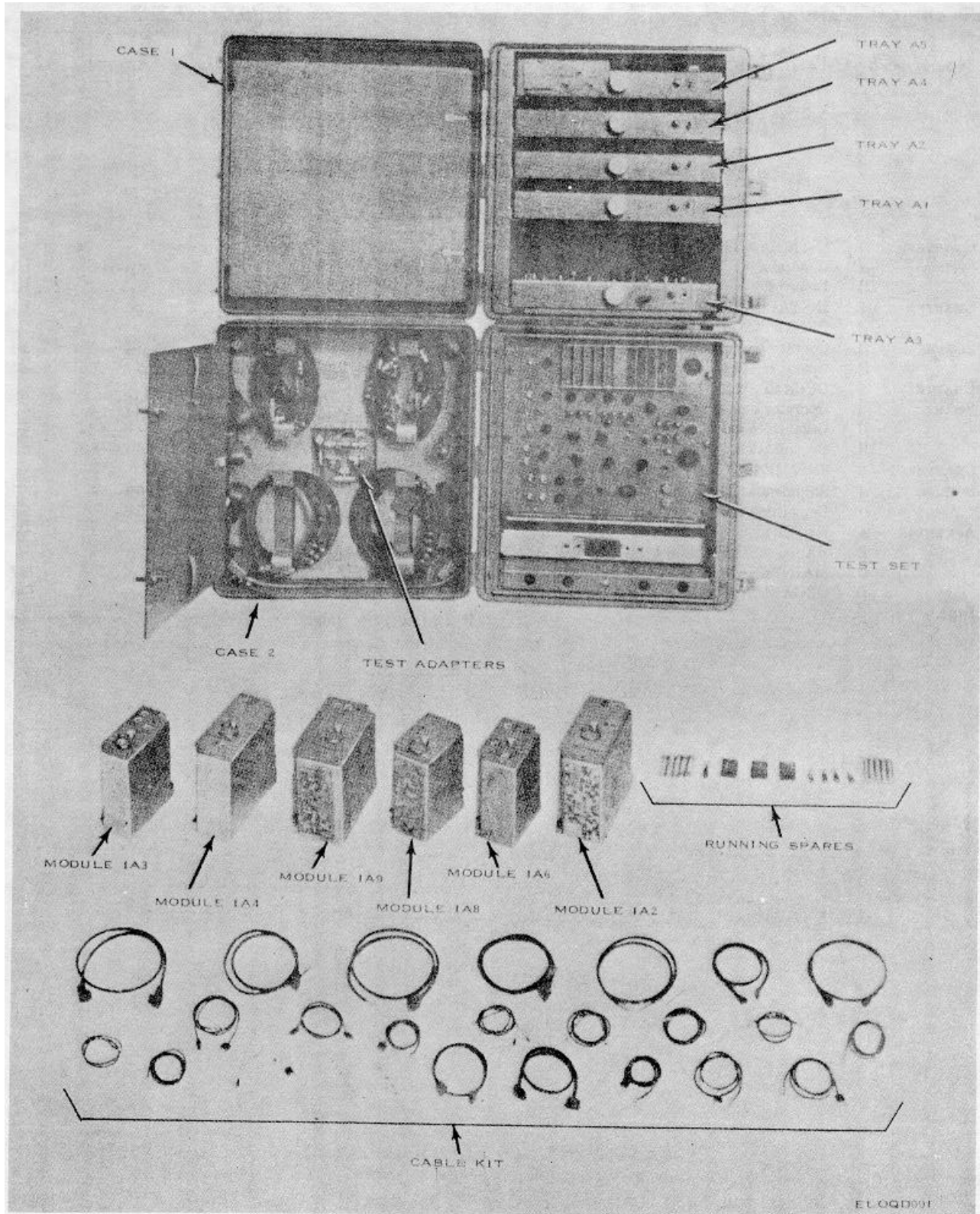

Figure 1-1. Simulator, Radio frequency SM-442A/GRC and running spares.

Change 2 ii

CHAPTER 1 INTRODUCTION

Section I. GENERAL

1-1. Scope of Manual

This manual describes Simulator, Radio Frequency SM-442A/GRC (fig. 1-1) and covers its installation, operation, and maintenance. It includes operation, cleaning, and inspection of the equipment, and replacement of parts available to the operator and organizational maintenance personnel.

1-2. Indexes of Publications

a. DA Pam 310-4. Refer to the latest issue of DA Pam 3104 to determine whether there are new editions, changes, or additional publications pertaining to the equipment.

b. DA Pam 310-7. Refer to DA Pam 310-7 to determine whether there are modification work orders (MWO's) pertaining to the equipment.

1-3. Forms and Records

a. Reports of Maintenance and Unsatisfactory Equipment. Maintenance forms, records, and reports which are to be used by maintenance personnel at all maintenance levels are listed in and prescribed by TM 38-750.

b. Report of Packaging and Handling Deficiencies. Fill out and forward DD Form 6 (Report of Packaging and Handling Deficiencies) as prescribed in AR 700-58 and DSAR 4145.8.

c. Discrepancy in Shipment Report (DISREP) (SF 361). Fill out and forward Discrepancy in Shipment Report (DISREP) (SF 361) as prescribed in AR 5548 and DSAR 4500.15.

d. Administrative Storage. The procedures for administrative storage are outlined in TM 740-90-1; however, the exact procedure in repacking for limited storage depends on the materials available and the conditions under which the equipment is to be stored.

1-3.1. Reporting of Errors

The reporting of errors, omissions, and recommendations for improving this publication by the individual user is encouraged. Reports should be submitted on DA Form 2028, (Recommended Changes to Publications, and Blank Forms), and forwarded direct to Commander, US Army Electronics Command, ATTN: DRSEL-MAQ, Fort Monmouth, NJ 07703.

Section II. DESCRIPTION AND DATA

1-4. Purpose and Use

The SM-442A/GRC (fig. 1-1) serves as a simulator that provides stimulus controls, mechanical coupling, resistive power loads, and direct current (dc) and alternating current (ac) power which are necessary to conduct a performance test of Radio Set AN/GRC-106 with the use of standard external test equipment. When the SM442A/GRC is used to test the modules of Receiver-Transmitter, Radio RT-662/GRC or Amplifier, Radio Frequency AM-3349/GRC-106, it supplies the stimulus inputs and controls which are normally supplied by the remaining unit. When the SM442A/GRC is used to test the modules of the AN/GRC-106, it supplies the stimulus, the mechanical coupling, the power, the switching information, and loads which are normally supplied by the parent unit.

1-5. Technical Characteristics

Primary power requirements	27 ± 2 volts dc at 10 amperes min. (from external power supply).
Power consumption	400 watts, max.
Transportability	Air, rail, or vehicular (intact in shipping crate).
Cabling requirements	Input power cable (W15, W16, or W17) plus cables specified for a particular test. Cables secured from supplied cable kit.
Dc output voltages	-30 volts at 3 ma. + 20 .volts at 500 ma. +27 volts at 10 amp., max. + 125 volts at 50 ma. +200 volts at 158 ma.
Ac output voltages	6.3 volts at 0.75 amp.
Input frequencies	50 cps to 1 kc.
Output frequencies	1.750000 mc ± 100 cps, 1.751500 mc ± 100 cps, 1.752500 mc ± 100 cps.

Pulse outputs	1 ± .05 μ sec, 85 ± 15μ sec, 150 ± 60 μ sec (neg).	10 and 1 kc synthesizer module 1A4, RT-662/GRC.
Frequency selection	Selectable between 2 to 29.999 mc by means of five-wire coding.	Frequency divider module 1A6, RT-662/GRC.
Testing capabilities	Test set (alone) is used to test: RT-662/GRC. AM-3349/GRC-106.	Translator module 1A8, RT-6621GRC.
	Test set with common module tray A1 is used to test:	Mc synthesizer module 1A9 RT-662GRC.
	RF amplifier module 1A12, RT-662/GRC.	Test set with converter and control tray A4 is used to test:
	Dc-to-dc converter and regulator module 1A11, RT-662GRC.	RT-6621GRC.
	Noise blanker subassembly 1A1A6, RT462/GRC.	Front panel assembly 2A5, AM-3349/GRC-106.
	Test set with common module tray A2 is used to test:	Dc to ac inverter assembly 2A6A1, AM-3349/GRC-106.
	Receiver IF module 1A7, RT 662/GRC.	Inputs to antenna coupler assembly 2A3, AM-3349/GRC-106.
	Receiver audio module 1A10, RT-662/GRC.	Test set with driver, discriminator, and antenna coupler tray A5 is used to test:
	Transmitter IF and audio module 1A5, RT462/GRC.	Antenna coupler assembly 2A3, AM3349/GRC-106.
	Test set with synthesizer test tray A3 is used to test:	Discriminator assembly 2A4, AM-3349/GRC-106.
	100 kc synthesizer module 1A2, RT-62/GRC.	Relay assembly 2A7, AM3349/GRC-106.
	Frequency standard module 1A3, RT462/GRC.	Driver assembly 2A8, AM-3349/GRC-106.

1-6. Items Comprising an Operable Simulator, Radio Frequency SM-442A/GRC

FSN Qty Nomenclature, part No., and mfr code Fig. No.

NOTE

The part number is followed by the applicable 5-digit Federal supply code for manufacturers (FSCM) identified in SB 708-42 and used to identify manufacturer, distributor, Government agency, etc.

6625-937-4029		Simulator, Radio Frequency SM-442A/GRC consisting of:	
5935-201-2411	2	Adapter, Connector: MS35173-274B; 96906.....	1-1
5935-837-9648	1	Adapter, Connector: UG107B/U; 80058.....	1-1
5935-832-9291	1	Adapter, Radio Frequency Cable: A51870-001; 58189.....	1-1
5935-901-8708	1	Adapter, Radio Frequency Cable: A518364)01; 58189.....	1-1
5995-832-4860	1	Cable Assembly R.F.: (4 ft 6 in.); A518684001; 58189.....	1-1
5995-905-7194	4	Cable Assembly R.F. CG-409G/U: (6 ft 0 in.); A51795; 58189.....	1-1
5995-935-0343	3	Cable Assembly R.F.: (6 ft 0 in.); A51796; 58189.....	1-1
5995-935-4344	2	Cable Assembly R.F.: (6 ft 0 in.); A51797; 58189.....	1-1
5995-935-4345	1	Cable Assembly R.F.: (6 ft 0 in.) A517984001; 58189.....	1-1
5995-935-4349	2	Cable Assembly R.F.: (6 in.); A51865; 58189.....	1-1
5995-935-4350	1	Cable Assembly R.F.: (4 ft 6 in.); A51869-001; 58189.....	1-1
5995-935-0352	1	Cable Assembly R.F.: (3 ft 0 in.); A51841-001; 58189.....	1-1
5995-947-7419	3	Cable Assembly, Power, Electrical: (6 ft 0 in.); A51843; 58189.....	1-1
5995-832-6853	1	Cable Assembly, Special Purpose Electrical: (6 in.); A51866-001; 58189.....	1-1
5995-832-6861	1	Cable Assembly, Special Purpose, Electrical: (4 ft 0 in.) A41867-001; 58189.....	1-1
5995-935-0351	1	Cable Assembly, Special Purpose, Electrical: (3 ft 0 in.); A51842-001; 58189.....	1-1
5995-947-7417	1	Cable Assembly, Special Purpose, Electrical: (6 ft 0 in.) A51799-001; 58189.....	1-1
5995-947-7418	1	Cable Assembly, Special Purpose, Electrical: (6 ft 0 in.); A51800-001; 58189.....	1-1
5995-947-7420	1	Cable Assembly, Special Purpose, Electrical: (4 ft 0 in.); A51844-001; 58189.....	1-1
5995-947-7421	1	Cable Assembly, Special Purpose, Electrical: (4 ft 0 in.); A518640M01; 58189.....	1-1
5995-061-1330	1	Crystal Unit, Quartz: 694087-83; 58189.....	1-1
5995-944-9525	1	Crystal Unit, Quartz: 694087-85; 58189.....	1-1

<i>FSN</i>	<i>Qty</i>	<i>Nomenclature, part No., and mfr code</i>	<i>Fig. No.</i>
5995-968-5494	1	Crystal Unit, Quartz: 69408787; 58189	1-1
4931-546-4347	1	Dummy Conductor Plug: 534-2; 95712	1-1
5820-226-5369	1	Frequency Divider Assembly: SM-D-500014; 80063.....	1-1
5820-226-5368	1	Frequency Standard: SM-D500011; 80063.....	1-1
5820-226-5436	1	Synthesizer, Electrical Frequency: SM-D-500012; 80063	1-1
5820-226-5437	1	Synthesizer, Electrical Frequency: SM-D-503249; 80063	1-1
5820-226-5438	1	Synthesizer, Electrical Frequency: SM-D-500010; 80063	1-1
5820-226-5365	1	Translator, Signal Data: SM-D-500016; 80063.....	1-1

1-6.1. Operational Items Stored in Cases

<i>FSN</i>	<i>Qty</i>	<i>Nomenclature</i>
5935-201-2411	2	Adapter, Connector.
5935-837-9648	1	Adapter, Connector.
5935-932-9291	1	Adapter, Radio frequency Cable.
5935-901-8708	1	Adapter, Radio frequency Cable.
5995-947-7419	1	Cable Assembly, Power, Electrical (6 ft 0 in.).
5995-832-6860	1	Cable Assembly R.F. (4 ft 6 in.).
5995-905-7194	4	Cable Assembly R.F. CG409G/U (6 ft 0 in.).
5995-935-0349	2	Cable Assembly R.F. (6 in.).
5995-935-4343	3	Cable Assembly R.F. (6 ft 0 in.).
5995-935-0344	2	Cable Assembly R.F. (6 ft 0 in.).
5995-935-0345	1	Cable Assembly R.F. (6 ft 0 in.).
5995-935-0350	1	Cable Assembly R.F. (4 ft 6 in.).
5995-935-0352	1	Cable Assembly R.F. (6 ft 0 in.).
5995-832-4853	1	Cable Assembly, Special Purpose Electrical (6 in.).
5995-832-6861	1	Cable Assembly, Special Purpose Electrical (4 ft 0 in.).
5995-935-0351	1	Cable Assembly, Special Purpose Electrical (3 ft 0 in.).
5995-947-7417	1	Cable Assembly, Special Purpose Electrical (6 ft 0 in.).
5995-947-7418	1	Cable Assembly, Special Purpose Electrical (6 ft 0 in.).
5995-947-7420	1	Cable Assembly, Special Purpose Electrical (4 ft 0 in.).
5995-947-7421	1	Cable Assembly, Special Purpose Electrical (4 ft 0 in.).
5995-061-1330	1	Crystal Unit, Quartz.
5995-944-9525	1	Crystal Unit, Quartz.
5995-968-5494	1	Crystal Unit, Quartz.
4931-546-4347	1	Dummy Connector Plug.

1-7. Description of Equipment

The SM442A/GRC is contained in two hand-portable, moisture-sealed cases. The first case (case 2) contains the test set which is secured to case 2 by six front panel mounting screws. The second case (case 1) is equipped with metal slides for the storage of the five test fixture trays, common module tray A1 (tray A1), common module tray A2 (tray A2), synthesizer test tray

A3 (tray A3), converter and control tray A4 (tray A4), and driver, discriminator, and antenna coupler tray A5 (tray A5). The trays are secured in the slides by the use of the connector holddown screws on the rear panel of the trays. A cable storage area is provided on the inside of the front cover of the cases by a hinged panel.

**CHAPTER 2
INSTALLATION**

2-1. Unpacking

(fig. 2-1)

- a. Unpack case 1 as follows; use at least two men:
 - (1) Remove the krimp fasteners from the top cover of the plywood crate.
 - (2) Remove the corrugated carton marked test set.
 - (3) With a knife or any sharp instrument, slit the tape which holds the top of the corrugated packing carton; open the carton.
 - (4) Remove the polyethylene shroud from case 1.
 - (5) Remove the four polystyrene corner pads from the top of case 1.
 - (6) With one man at the front and one at the rear, lift case 1 from its crate.

(7) Store the packaging material for future reshipment.

- b. Unpack case 2 as follows:

- (1) Remove the second corrugated carton from its plywood crate.
- (2) With a knife or any sharp instrument, slit the tape which holds the top of the corrugated packing carton; open the carton.
- (3) Remove the polyethylene shroud from case 2.
- (4) Remove the four polystyrene corner pads from top of case 2.
- (5) With one man at the front and one at the rear, lift case 2 from its crate.
- (6) Store the packaging material for future reshipment.

2-2. SM-442A/GRC Shipping Container Chart

Case No.	Dimensions (in.)			Weight	Qty
	Height	Width	Depth		
2	30½	<i>Crated</i> 23½	26	32	1
1	30½	23½	26	73	1
1 and 2	51	33	31	130	1
		<i>Uncrated</i>			
2	22	20½	20	30	1
1	22	20½	20	70	1

2-3. Checking Unpacked Equipment

- a. Inspect the equipment for damage incurred during shipment. If the equipment has been damaged, report the damage on DD Form 6 (para 1-3b).
- b. Check to see that the equipment is as listed on the packing slip. If a packing slip is not available, check the equipment against the items comprising an operable equipment list (para 1-6). Report all discrepancies in accordance with instructions given in TM 38-750. Storage of a minor assembly or part that does not affect the problem functioning of the equipment should not prevent the use of the equipment.
- c. If the equipment has been used or reconditioned, check to see if it has been changed by a modification work order (MWO). If the equipment has been modified, the MWO number will appear on the front panel near the nomenclature plate. Be sure that any operational instruction changes resulting from the modification have been entered into the equipment manual.

Note: Current MWO's applicable to the equipment are listed in DA Pam 3104.

2-4. Placement of Equipment

When the SM442A/GRC is to be installed, the following factors should be considered:

- a. *Test Set (Case 2).*

- (1) The test set must be located within 6 feet of a 27-volt de, 100-ampere power source.
- (2) Case 2 has resilient bumpers for placement on a workbench.
- (3) A minimum 24by 24-inch space is required if case 2 is placed on a workbench.

- b. *Storage Case (Case 1).*

- (1) Case 1 has no requirement for power.
- (2) Case 1 has resilient bumpers for placement on a workbench.
- (3) A minimum 24by 24-inch bench space is required.
- (4) If bench space is limited, the top of case 2 is dimpled so that case 1 may be stacked on top of case 2.

2-5. Initial Adjustment of Equipment

No initial adjustment of this equipment is required.

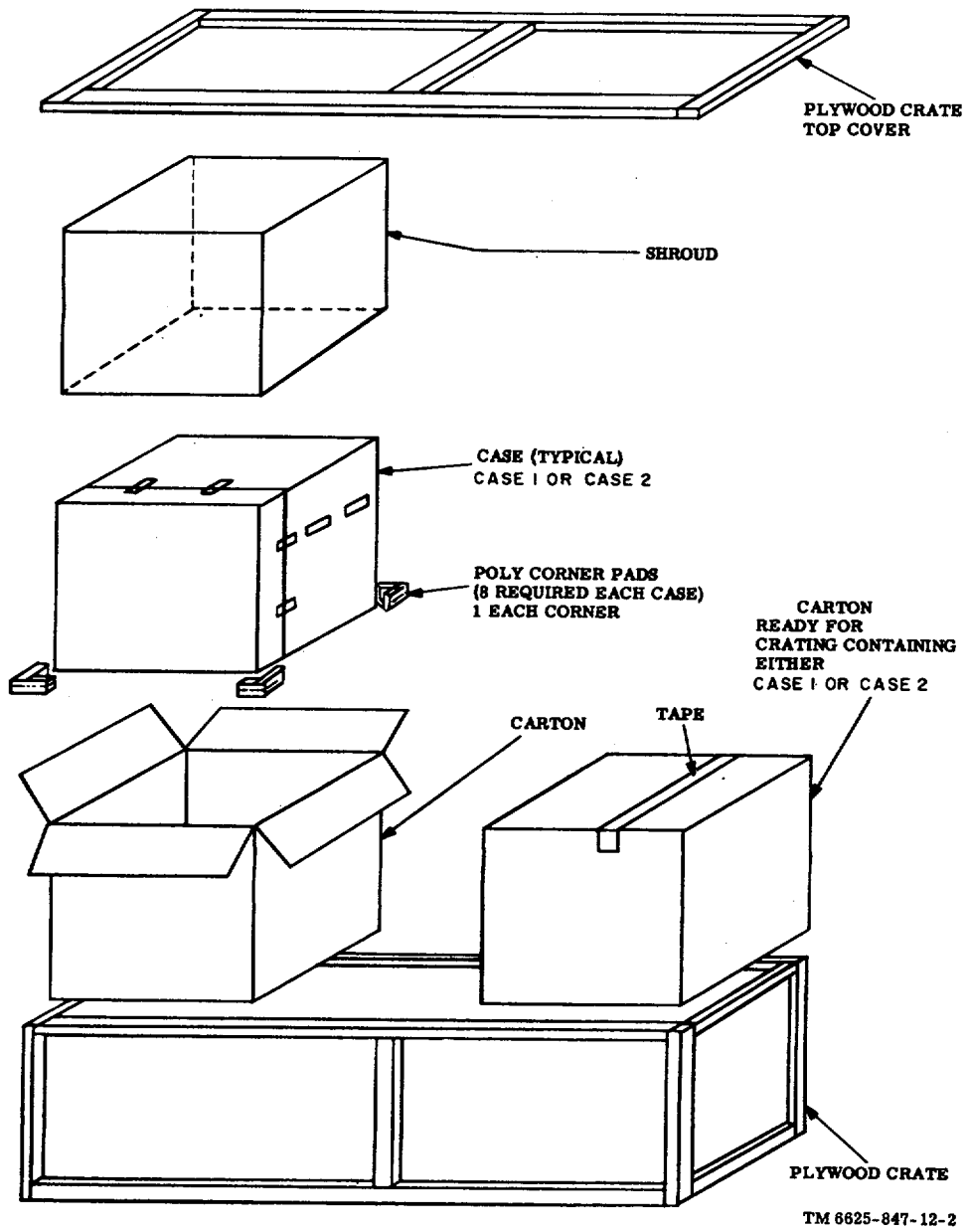

Figure 2-1. SM-442A/GRC packing diagram.

**CHAPTER 3
OPERATING INSTRUCTIONS**

Section I. OPERATING CONTROLS, INDICATORS, AND CONNECTORS

3-1. Operator's Controls, Indicators, and Connectors

The controls, indicators, connectors, and fuses on the front panel of the test set are listed maintenance of the equipment are covered in paragraph 3-2. Paragraphs 3-3 through 3-7 list controls, indicators, connectors, and

fuses for the test trays used in conjunction with the test set.

Note. This section covers only those items used when the equipment is being operated; items used during tions given for the appropriate category of maintenance

3-2. Test Set Controls, Indicators, and Connectors

Control, indicator, or connector	Function										
SERV SEL switch -----	<p>Controls +27-volt de primary power to test set in first four positions (OFF, OVEN ON, STBY, and SSB/NSK), and mode of operation of subassemblies, modules, or units of AN/GRC-106, when connected to the test set.</p> <table style="width: 100%; border-collapse: collapse;"> <thead> <tr> <th style="text-align: left; width: 15%;">Pos</th> <th style="text-align: left;">Action</th> </tr> </thead> <tbody> <tr> <td>OFF</td> <td>+27-volt de primary power removed from all circuits</td> </tr> <tr> <td>OVEN ON</td> <td> <ul style="list-style-type: none"> a. +27-volt dc primary power to regulator section of dc-to-dc converter and reg assembly A3. b. +27-volt dc primary power for OVEN ON. c. +27-volt de primary power to REC/XMIT switch S4 contact terminal 9, for RCVR +27 VDC/XMTR GND. </td> </tr> <tr> <td>STBY</td> <td> <ul style="list-style-type: none"> a. All OVEN ON functions repeated. b. +27-volt dc primary power for STBY and all modes c. PA/RT switch contact terminal 5, section C, grounded, in STBY and OPER. </td> </tr> <tr> <td>SSB/NSK</td> <td> <ul style="list-style-type: none"> a. All STBY and OVEN ON functions repeated. b. PA/RT switch contact terminal 2 and contact terminal 5, section C, grounded, for +27 V DC OPR. c. +27-volt dc primary power for DC OPR. </td> </tr> </tbody> </table>	Pos	Action	OFF	+27-volt de primary power removed from all circuits	OVEN ON	<ul style="list-style-type: none"> a. +27-volt dc primary power to regulator section of dc-to-dc converter and reg assembly A3. b. +27-volt dc primary power for OVEN ON. c. +27-volt de primary power to REC/XMIT switch S4 contact terminal 9, for RCVR +27 VDC/XMTR GND. 	STBY	<ul style="list-style-type: none"> a. All OVEN ON functions repeated. b. +27-volt dc primary power for STBY and all modes c. PA/RT switch contact terminal 5, section C, grounded, in STBY and OPER. 	SSB/NSK	<ul style="list-style-type: none"> a. All STBY and OVEN ON functions repeated. b. PA/RT switch contact terminal 2 and contact terminal 5, section C, grounded, for +27 V DC OPR. c. +27-volt dc primary power for DC OPR.
Pos	Action										
OFF	+27-volt de primary power removed from all circuits										
OVEN ON	<ul style="list-style-type: none"> a. +27-volt dc primary power to regulator section of dc-to-dc converter and reg assembly A3. b. +27-volt dc primary power for OVEN ON. c. +27-volt de primary power to REC/XMIT switch S4 contact terminal 9, for RCVR +27 VDC/XMTR GND. 										
STBY	<ul style="list-style-type: none"> a. All OVEN ON functions repeated. b. +27-volt dc primary power for STBY and all modes c. PA/RT switch contact terminal 5, section C, grounded, in STBY and OPER. 										
SSB/NSK	<ul style="list-style-type: none"> a. All STBY and OVEN ON functions repeated. b. PA/RT switch contact terminal 2 and contact terminal 5, section C, grounded, for +27 V DC OPR. c. +27-volt dc primary power for DC OPR. 										

Control, indicator, or connector	Function
	<p>Pos Action</p> <p>FSK a. All STBY and OVEN ON functions repeated. b. PA/RT switch contact terminal 2 and contact terminal 5, section C, grounded. c. Keyline connected to VOX OFF KEY.</p> <p>AM a. All STBY and OVEN ON functions repeated. b. PA/RT switch contact terminals 2 and 5 grounded</p> <p>CW a. All STBY and OVEN ON functions repeated. b. PA/RT switch contact terminals 2 and 6 grounded.</p>
POWER switch ----- 2400 VDC LOAD switch -----	Controls +27-volt dc primary power to test set. Controls size of resistive load.
	<p>Pos Action</p> <p>1----- 24,000 ohms 2----- 16,000 ohms 3----- 12,000 ohms 4----- 9,000 ohms 5----- 800 ohms 6----- 766 ohms 7----- 657 ohms</p>
REC-XMIT switch -----	<p>Pos Action</p> <p>REC ----- a. +20 volts dc to RCVR +20V DC/XMTR GRD. ----- b. +27-volts dc primary power to PA/RT switch contact terminal 2, section. A.</p> <p>XMIT ----- a. +20 volts dc to RCVR GRD/ XMTR +20 V DC. ----- b. PA/TR switch contact terminal 2, section A grounded.</p>
XMIT STATUS switch -----	When set to TUNE, provides TUNE INFO GRD, and PA/RT switch contact to terminal 7, section A.
KEY switch -----	When set to ON, provides the ground to pin F of AUDIO INPUT IN/OUT connector.
500 VDC LOAD1 switch -----	Controls the resistive load.
	<p>Pos Action</p> <p>LOW ----- 4,900 ohms HI ----- 4,000 ohms</p>
IF OSCILLATOR select switch-----	Controls selection of three IF oscillators.
	<p>Pos Action</p> <p>1 ----- Selects 1.7500 me IF oscillator. 1 + 2----- Selects 1.7500 me and 1/7515 me IF oscillators 1 + 3 Selects 1.7500 me and 1.7525 me IF oscillators. 2 + 3----- Selects 1.7515 me and 1.7525 me IF oscillators. 4 ----- Selects 1.7500 me, 1/7515 me and 1.7525 me IF oscillators</p>
MC FREQ select switches; 10MC, 1MC and .1MC ----	Controls mc shaft coupler on tray A1 and tray A3 and fixe-wire coding information to AM3349/GRC-106.

Control, indicator, or connector	Function	
	Pos	Action
PA/RT switch -----	PA ----- RT -----	Provides five-wire coding information, frequency change ground, frequency information ground, and ALC VOLTAGES test points; TUNE IN and INFO IN are connected to PA CONTROL connector J12. Provides inputs on PA CONTROL connector pins connected to J1, ALC VOLTAGE INFO, and TUNE test points OUT and ALC control voltages; ALC VOLTAGE INFO and TUNE are connected to PA CONTROL connector J12.
POWER indicator -----		Indicates POWER switch S2 is set to ON, and +27volt dc primary power is supplied from external source.
ALC VOLTAGE INFO control -----		Adjusts level of dc voltage at test point ALC VOLTAGE INFO OUT and to PA/RT switch contact terminal 4, section D.
ALC VOLTAGE TUNE control -----		Adjust level of dc voltage at test point ALC VOLTAGE TUNE OUT and to PA/RT switch contact terminal 1, section C.
DC VOLTAGE 200 control -----		Adjusts level of +200-volt de output voltage.
DC VOLTAGE 20 control-----		Adjusts level of +20-volt dc output voltage.
IF OSCILLATORS 1 1.75 MC output level control ----		Adjusts 1.75-me RF output level of IF oscillator module.
IF OSCILLATORS 2 1.7515 MC output level control --		Adjusts 1.7515-mc RF output level of IF oscillator module.
IF OSCILLATORS 3 1.7525 MC output level control --		Adjusts 1.7527-mc RF output level of IF oscillator module.
PULSE GENERATOR (upper) AMPLITUDE control.		Controls amplitude of this 85-µsec pulse, and 150-µsec pulse at OUTPUT connectors 1 and 2, respectively.
PULSE GENERATOR (upper) WIDTH control -----		Controls width of output pulse to 85-µsec at connector 1, or to 150-µsec at connector 2.
PULSE GENERATOR (lower) AMPLITUDE----- control.		Controls amplitude of 1-µsec pulse at connector 3.
PULSE GENERATOR (lower) WIDTH control -----		Controls width of 1-µsec pulse at connector 3.
10 AMP fuse -----		Current protection for test set.
SPACE fuse -----		Receptacle for storage of spare fuse.
IF OSCILLATOR 4 TWO TONE output level control --		Adjust RF output level of mixer assembly.
POWER connector -----		Multipin connector for power cable W15.
DC VOLTAGE (ground) test connector -----		Ground test point for dc voltage measurements.
DC VOLTAGE +200 test connector -----		Test point for measuring +200 volts dc.
AUDIO IN/OUT connector -----		Multipin connector for audio cable W12.
AUDIO IN 600 (ohm) connector -----		For connecting external audio test equipment to AUDIO IN/OUT connector.
AUDIO IN (ground) connector -----		Ground connector for external audio test equipment at AUDIO IN/OUT connector.
AUDIO IN 50 (ohm) connector -----		For connecting external audio test equipment to AUDIO IN/OUT connector.
AUDIO OUT 2 WATT connector -----		Connector for measuring audio input signals at AUDIO IN/OUT connector.
AUDIO OUT (ground) connector -----		Ground connection for measuring audio input signals at AUDIO IN/OUT connector.
AUDIO OUT 10 MW connector -----		Connector for measuring audio input signals at AUDIO/OUT connector.
DC VOLTAGE +20 test connector -----		Test point for measuring +20 volts de.
PA CON'TROL connector -----		Multipin connector for control cable W11.

Control, indicator, or connector	Function
ALC VOLTAGE INFO IN test connector -----	Test point for measuring ALC VOLTAGE INFO input at PA CONTROL connector.
ALC VOLTAGE INFO (ground) test connector -----	Ground test point for ALC VOLTAGE INFO.
ALC VOLTAGE INFO OUT test connector -----	Test point for measuring ALC VOLTAGES INFO output at PA CONTROL connector.
ALC VOLTAGE TUNE IN test connector -----	Test point for measuring ALC VOLTAGES TUNE input at PA CONTROL connector.
ALC VOLTAGE TUNE (ground) test connector -----	Ground test point for ALC VOLTAGES TUNE.
ALC VOLTAGE TUNE -----	OUT test connector Test point for measuring ALC VOLTAGES TUNE output at PA CONTROL connector J12.
IF OSCILLATOR 3 1.7525 MC OUT connector -----	Connector for monitoring output of 1.7525 me IF oscillator.
IF OSCILLATOR 2 1.7515 MC OUT connector -----	Connector for monitoring output of 1.7515 me IF oscillator.
IF OSCILLATOR 1 1.75 MC OUT connector -----	Connector for monitoring output of 1.75 me IF oscillator.
PULSE GENERATOR INPUT connector -----	For connecting external audio signal generator to trigger pulse generator.
PULSE GENERATOR OUTPUTS 2 connector -----	Output connector for 150- μ sec pulse.
PULSE GENERATOR OUTPUTS 1 connector -----	Output connector for 85-- μ sec pulse.
PULSE GENERATOR OUTPUTS 3 connector -----	Output connector for 1- μ sec pulse.

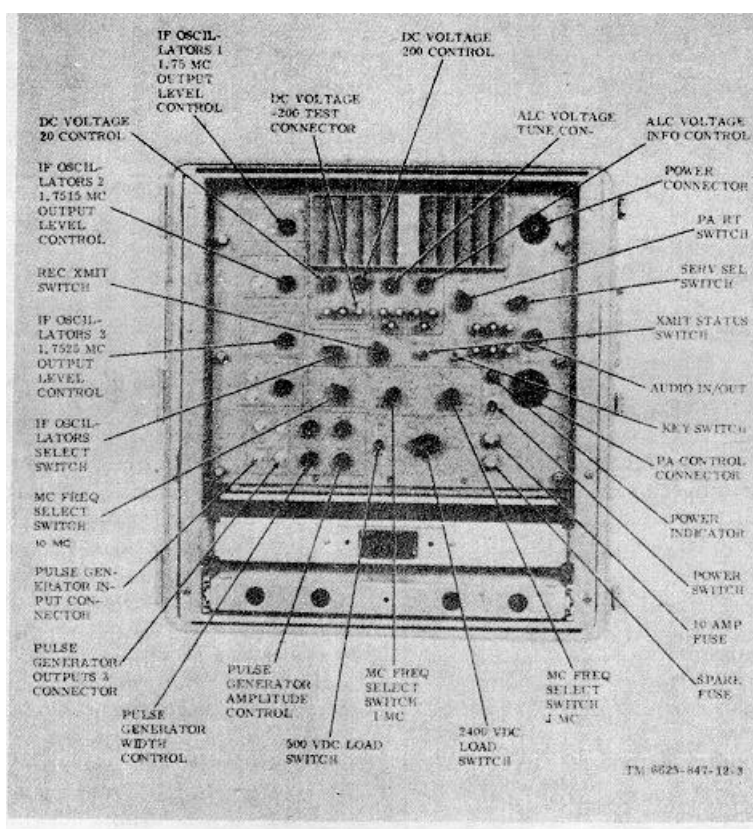

Figure 3-1 (1). Test set, controls, indicators, and connectors.

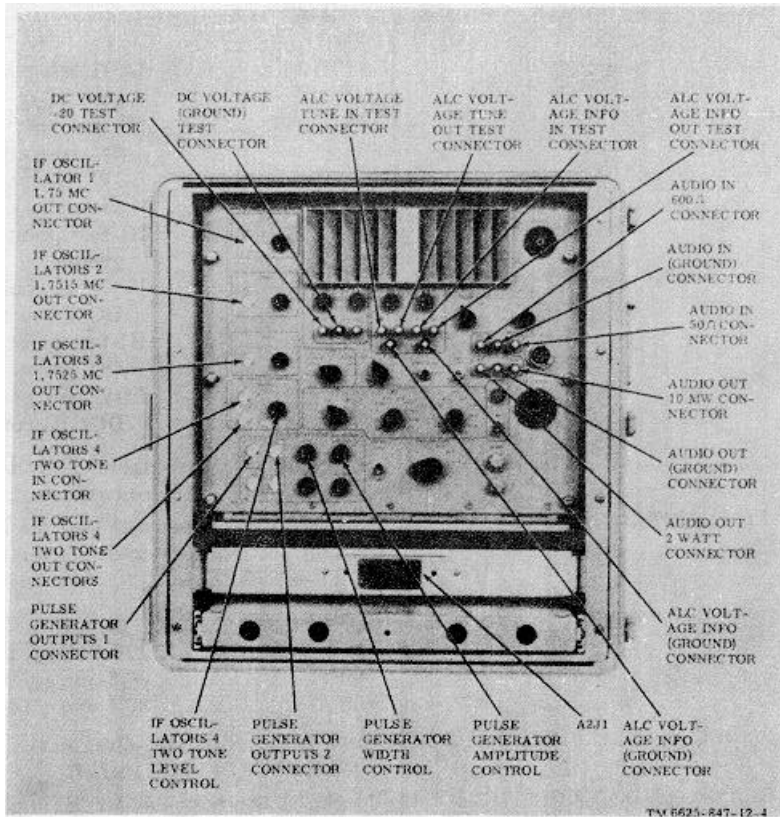

Figure 3-1 (2).—Continued.

3-3. Common Module Tray A1, Controls, Indicators, and Connectors
(fig. 3-2 (1) and (2))

Control, indicator, or connector	Function						
POWER switch -----	Controls +27-volt dc primary power from test set SERV SEL switch (positions: SS,B/NSK, FSK, AM and CW) to circuits and connectors on common module tray A1.						
DC/DC CONVERTER CONV/REC TEST REG switch	Permits input current measurement tests of regulator section of dc-to-dc converter and regulator module, RT-662/GRC.						
DC/DC CONVERTER CONV/REC TEST CONV switch	Permits input current measurement tests of converter section of de-to-c converter and regulator module, RT-662/GRC.						
DC/DC CONVERTER TEST SELECTOR switch -----	Controls DC/DC CONVERTER test points HI and LO for voltage measurements of dc-to-dc converter and regulator module, RT-62/GRC at connector J9.						
	<table border="0"> <thead> <tr> <th data-bbox="787 1591 950 1621">Pos</th> <th data-bbox="1291 1591 1380 1621">Action</th> </tr> </thead> <tbody> <tr> <td data-bbox="787 1621 950 1684">1-----</td> <td data-bbox="966 1621 1469 1684">Hi test point connected to +27 v dc. LOW test point connected to ground.</td> </tr> <tr> <td data-bbox="787 1684 950 1711">2-----</td> <td data-bbox="966 1684 1469 1711">Hi test point connected to switch S1 front.</td> </tr> </tbody> </table>	Pos	Action	1-----	Hi test point connected to +27 v dc. LOW test point connected to ground.	2-----	Hi test point connected to switch S1 front.
Pos	Action						
1-----	Hi test point connected to +27 v dc. LOW test point connected to ground.						
2-----	Hi test point connected to switch S1 front.						

Control, indicator, or connector	Function																
	<table border="0"> <thead> <tr> <th data-bbox="792 205 954 231">Pos</th> <th data-bbox="1295 205 1380 231">Action</th> </tr> </thead> <tbody> <tr> <td data-bbox="792 239 954 264">3-----</td> <td data-bbox="980 239 1510 264">LOW test point connected to ground.</td> </tr> <tr> <td data-bbox="792 268 954 294"></td> <td data-bbox="980 268 1510 294">HI test point connected to DC/ DC converter.</td> </tr> <tr> <td data-bbox="792 298 954 323">4-----</td> <td data-bbox="980 298 1510 323">LOW test point connected to ground.</td> </tr> <tr> <td data-bbox="792 327 954 352"></td> <td data-bbox="980 327 1510 352">HI test point connected to ground.</td> </tr> <tr> <td data-bbox="792 357 954 382">5-----</td> <td data-bbox="980 357 1510 382">LOW test point connected to DC/DC converter.</td> </tr> <tr> <td data-bbox="792 386 954 411"></td> <td data-bbox="980 386 1510 411">HI test point connected to DC/ 'DC converter.</td> </tr> <tr> <td data-bbox="792 415 954 441"></td> <td data-bbox="980 415 1510 441">LOW test point connected to DC/DC converter.</td> </tr> </tbody> </table>	Pos	Action	3-----	LOW test point connected to ground.		HI test point connected to DC/ DC converter.	4-----	LOW test point connected to ground.		HI test point connected to ground.	5-----	LOW test point connected to DC/DC converter.		HI test point connected to DC/ 'DC converter.		LOW test point connected to DC/DC converter.
Pos	Action																
3-----	LOW test point connected to ground.																
	HI test point connected to DC/ DC converter.																
4-----	LOW test point connected to ground.																
	HI test point connected to ground.																
5-----	LOW test point connected to DC/DC converter.																
	HI test point connected to DC/ 'DC converter.																
	LOW test point connected to DC/DC converter.																
RF AMPL AGC switch-----	When set to ON, variable -dc voltage from RF AMPL AGC ADJ control is connected to RF AMPL.																
DC/DC CONVERTER LOAD SELECT switch -----	Controls size of resistive load for +20-volt dc regulator section of dc-to-dc converter module, RT-462/GRC.																
	<table border="0"> <thead> <tr> <th data-bbox="792 667 954 693">Pos</th> <th data-bbox="1101 667 1185 693">Action</th> </tr> </thead> <tbody> <tr> <td data-bbox="792 701 954 726">100-----</td> <td data-bbox="980 701 1295 726">196.3 ohms, 100 ma, load.</td> </tr> <tr> <td data-bbox="792 730 954 756">500-----</td> <td data-bbox="980 730 1295 756">38,3 ohms, 500 ma, load.</td> </tr> <tr> <td data-bbox="792 760 954 785">600-----</td> <td data-bbox="980 760 1295 785">32A ohms, 600 ma, load.</td> </tr> </tbody> </table>	Pos	Action	100-----	196.3 ohms, 100 ma, load.	500-----	38,3 ohms, 500 ma, load.	600-----	32A ohms, 600 ma, load.								
Pos	Action																
100-----	196.3 ohms, 100 ma, load.																
500-----	38,3 ohms, 500 ma, load.																
600-----	32A ohms, 600 ma, load.																
RF AMPL AGC ADJ control -----	Controls level of -dc voltage to contact terminal 1 of RF AMPL AGC switch.																
RF AMPL 100 KC SELECTOR AND 10 KC ----- SELECTOR switches -----	Mechanically positions 100 kc and 10 kc shaft couplers for rf amplifier module, RT-662/GRC.																
POWER INDICATOR -----	Indicates POWER switch S1, is set to ON, and +27volt dc primary power is supplied from test set.																
J1 -----	Multipin connector for electrical interconnection of tray A1 and test set.																
NOISE BLANKER NOISE BLANKER 20 VDC----- connector -----	For connecting +20 volts dc to noise blanker, RT-662/GRC.																
NOISE BLANKER (ground) connector -----	Ground connector for noise blanker RT-662/GRC.																
DC/DC CONVERTER CONV/REC TEST HI ----- test connector-----	Test point for measuring input current to converter or regulator sections of dc-to-dc converter and regulator module, RT462/GRC.																
DC/DC CONVERTEIR CONV/REC TEST CONV LOW test connector	Test point for measuring input current of converter section of dc-to-dc converter and regulator module, RT62/GRC.																
DC/DC CONVERTER CONV/REC TEST REG LOW test connector	Test point for measuring input current of regulator section of dc-to-dc converter and regulator module, RT -462/GRC.																
DC/DC CONVERTER LOAD SELECT HI test connector	Test point for voltage measurements of dc-to-dc converter and regulator module, RT-62/GRC.																
DC/DC CONVERTER LOAD SELECT LOW test connector	Test point for voltage measurements of dc-to-dc converter and regulator module, RT462/GRC.																
DC/DC CONVERTER connector -----	Multipin connector for electrical interconnection of dc-to-dc converter and regulator module, RT-62/ GRC to tray A1.																
DC/DC CONVERTER LOAD SELECT (ground)----- connector	Ground test point for voltage measurements of +20-volt dc output of regulator section of dc-to-dc converter and regulator module, RT-662/GRC.																

Control, indicator, or connector	Function
DC/DC AGC TEST connector-----	Test point for voltage measurements of +2 -volt de output of regulator section, dc-to-dc converter and regulator module, RT-662/GRC.
RF AMPL AGC TEST connector -----	Test point for voltage measurements of age output voltage; controlled by AGC ADJ control.
RF AMPL AGC (ground) test connector -----	Ground test point for voltage measurements of age voltage.
RF AMPL RF IN connector-----	For connecting external test equipment.
RF AMPL connector -----	Multipin connector for electrical interconnection of rf amplifier module, RT4-62GRC to tray A1.
NOISE BLANKER 1 USEC PULSE IN MODULE connector.	For connecting output pulse of noise blanker, RT46/GRC to tray A1.
NOISE BLANKER 1 USEC PULSE IN EXT connector.	For connecting inputs from external test equipment to noise blanker, RT-622/GRC.
RF AMPL RF OUT connector -----	For connecting external test equipment to output of rf amplifier, RT-622/GRC.
NOISE BLANKET PULSE OUT TEST connector. -----	For connecting test equipment to output of noise blanker, RT-662/GRC.
NOISE BLANKER PULSE OUT MODULE connector.-	For connecting inputs from tray A1 to noise blanker, RT-622/GRC.

Change 2 3-7

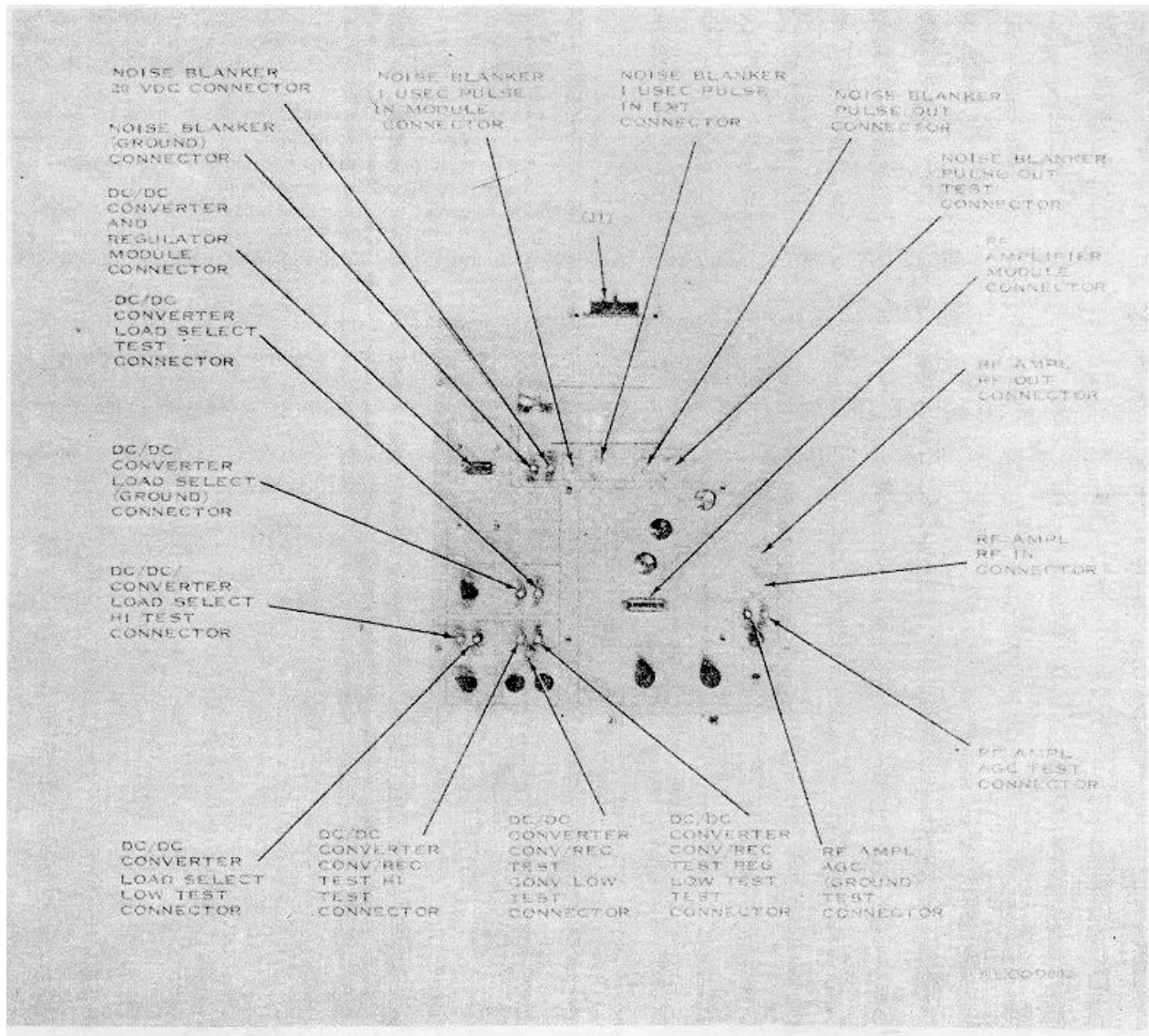

Figure 3-2 (1). Common module tray A1, controls, indicators, and connectors.

Change 2 3-8

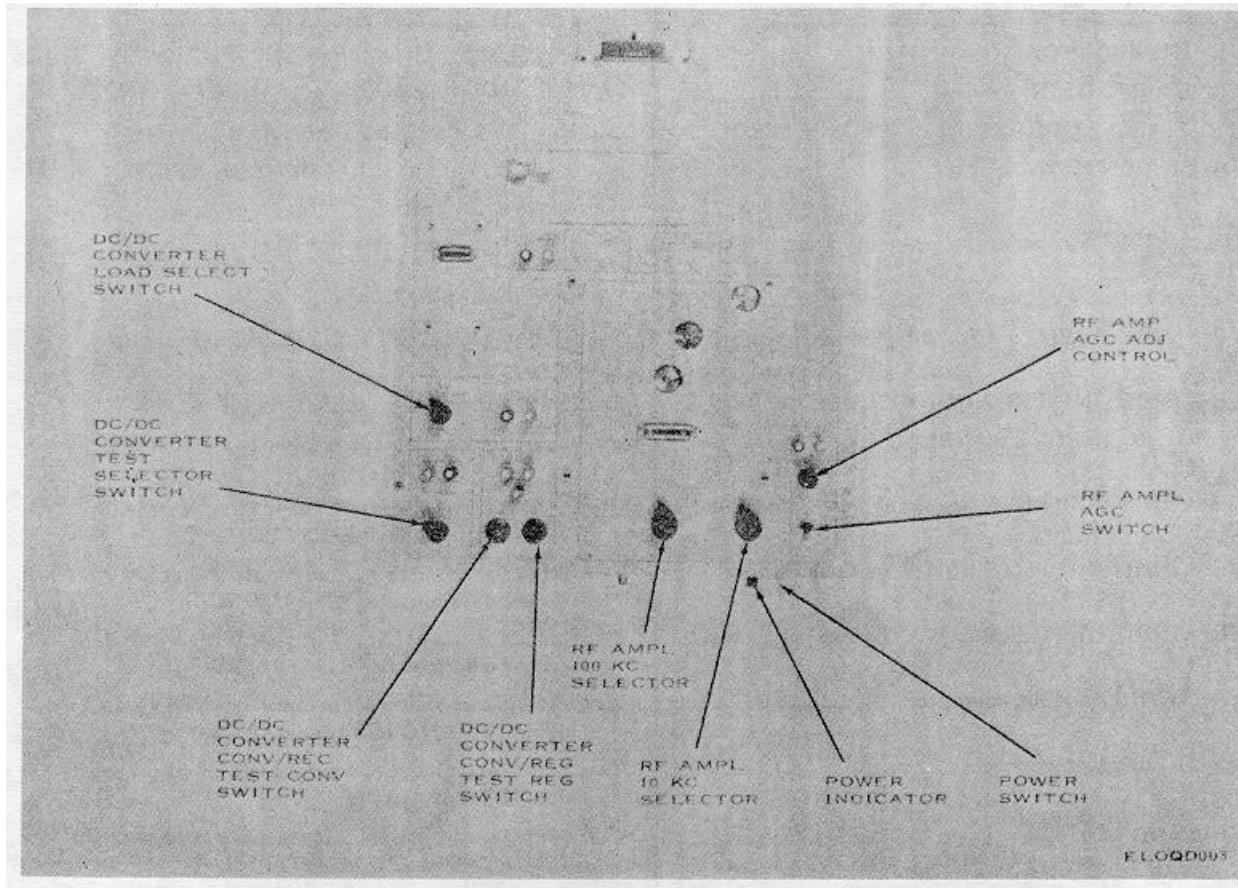

Figure 3-2 (2). Figure 3-2 (2). — Continued

3-4. Common Module Tray A2, Controls, Indicators, and Connectors
(fig. 3-3 (1) and (2))

Control, indicator, or connector	Function										
RCVR AUDIO SQUELCH SYNC switch-----	When set to ON, provides +27 volts dc to RCVR AUDIO INPUTS SQUELCH SYNC test connection and connects COMMON AUDIO 600 (ohm) IN connector to pin 6 of connector J8 for receiver audio module, RT-662/GRC.										
RCVR AUDIO SQUELCH switch-----	When set to OFF, provides ground to squelch circuit.										
POWER switch-----	Controls +27-volt dc primary power from test set SERV SEL switch (positions SSB/NSK, FSK, AM and CW) to tray A2 circuits and connectors.										
RCVR IF TEST SELECTOR switch-----	Controls RCVR IF test points HI and LO for voltage measurements of receiver if. module, AN/GRC-106.										
	<table border="0"> <thead> <tr> <th>Pos</th> <th>Action</th> </tr> </thead> <tbody> <tr> <td>1</td> <td>HI---Connected to ground LO--Connected to 33 v d.</td> </tr> <tr> <td>2</td> <td>HI---Connected to man. RF gain. LO--Connected to ground.</td> </tr> <tr> <td>3</td> <td>HI---Connected to BFO tune.</td> </tr> <tr> <td>3</td> <td>LO--Connected to ground.</td> </tr> </tbody> </table>	Pos	Action	1	HI---Connected to ground LO--Connected to 33 v d.	2	HI---Connected to man. RF gain. LO--Connected to ground.	3	HI---Connected to BFO tune.	3	LO--Connected to ground.
Pos	Action										
1	HI---Connected to ground LO--Connected to 33 v d.										
2	HI---Connected to man. RF gain. LO--Connected to ground.										
3	HI---Connected to BFO tune.										
3	LO--Connected to ground.										

Control, indicator, or connector	Function
RCVR IF BFO TONE control -----	Controls level of dc voltage to BFO TUNE.
RCVR IF RF GAIN control -----	Controls level of dc voltage to MAN. RF GAIN.
XMTR IF AND AUDIO ALC APC PPC CONTROL----- POWER CONTROL -----	Controls level of dc voltage to XMTR IF AND AUDIO ALC APC PPC CONTROL APC/PPC SEL switch and ALC switch.
POWER indicator -----	Indicates POWER switch is set to ON, and +27 volts dc is supplied to test tray from test set.
J1 -----	Multipin connector for connecting tray A2 to test set.
RCVR AUDIO INPUTS (ground) test connector -----	Ground test point for input audio signal measurements.
RCVR AUDIO INPUTS AUDIO IN test connector -----	Test point for monitoring audio input signals.
RCVR AUDIO INPUTS SQUELCH SYNC test ----- connector.	Test point for oscilloscope trigger input connector.
RCVR AUDIO OUTPUTS (ground) test connector ----	Ground test point for audio output measurements of receiver audio module RT-62/GRC.
RCVR AUDIO OUTPUTS 10MW test connector -----	Test point for monitoring audio output signals of receiver audio module, RT462/GRC.
RCVR AUDIO OUTPUTS 2 WATT test connector -----	Test point for monitoring audio output signal of receiver audio module, RT-662/GRC.
RCVR AUDIO module connector -----	Multipin connector for connecting receiver audio module, RT-662/GRC to tray A2.
RCVR IF LO test connector -----	Test point for voltage measurements of receiver IF module, RT662/GRC at J17.
RCVR IF HI test connector -----	Test point for voltage measurements of receiver IF module, RT9-62/GRC at J17.
COMMON IF OUT test connector -----	Connector for measuring if. output signals from J17 and J25 across 51-ohm load.
COMMON AUDIO 600 (ohm) IN connector -----	For connecting external audio signal generator to tray A2.
RCVR IF AMPL IF OUT connector -----	For monitoring amplified output IF signal of receiver if. module, RT-662/GRC at J17.
RCVR IF AGC SYNC test connector -----	Test point for oscilloscope trigger input connector.
RCVR IF RF AGC (ground) test connector -----	Ground test point for age measurements.
RCVR IF RF AGC OUTPUT test connector -----	Test point for measuring RF age voltage of receiver IF module, RT-662/GIRC.
RCVR IF module connector -----	Multipin connector for connecting receiver IF module to tray A2.
XMTR IF AND AUDIO HI test connector -----	Test point for voltage measurements of transmitter IF and audio module, RT-662/GRC.
XMTR IF AND AUDIO KEYLINE RT test----- connector -----	Test point for measurements RT-662/GRC keyline voltage.
XMTR IF ANR AUDIO KEYLINE PA test----- connector -----	Test point for measuring power amplifier, RT-62/GRC keyline voltage.
XMTR IF AND AUDIO LO test connector -----	Test point for voltage measurements of transmitter IF and audio module, RT-662/GRC.
XMTR IF AND AUDIO INPUT 50 (ohm) AUDIO----- connector.	For connecting external audio signal generator.

Control, indicator, or connector	Function
XMTR IF AND AUDIO INPUT 1 KC PULSE----- connector.	For connecting external pulse input.
XMTR IF AND AUDIO OUT connector -----	For monitoring audio output signal of transmitter IF and audio module, RT-2/GRC.
XMTR IF AND AUDIO module connector -----	Multipin connector for electrical interconnection of transmitter if. and audio module, RT-662/GRC and tray A2.

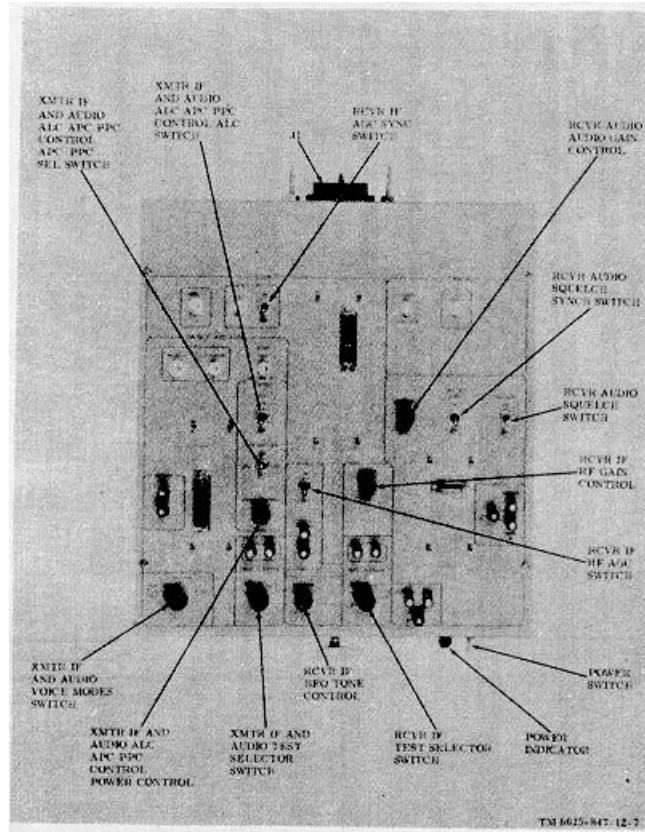

Figure 3-3 (1). Comman module tray A2, controls, indicators, and connector.

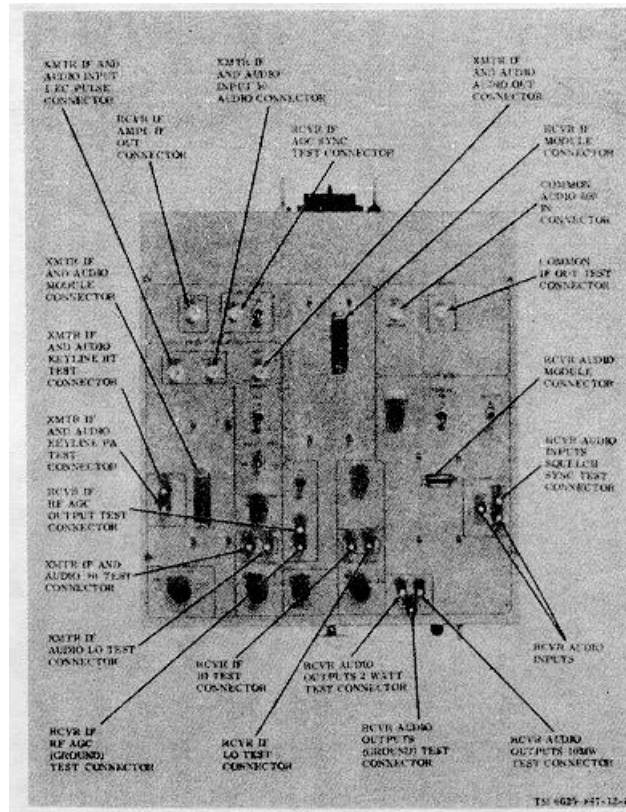

Figure 3-3 (2). — Continued.

3-5. Synthesizer Test Tray A3, Controls, Indicators, and Connectors
(fig. 3-4 (1) and (2))

Control, indicator, or connector	Function
POWER switch -----	Controls +27-volt dc primary power from test set SERV SEL switch (positions OVEN ON, STBY, SSB/NSK, FSK, AM, and CW) to circuits and connectors on tray A3.
POWER VAR/FIXED switch -----	Selects either fixed level dc voltage (+20 volts dc) or variable dc voltage to MODULE SELECT switch, contact terminal 12.
MODULE SELECT switch -----	Provides, to module selected, a fixed or variable de B+ supply voltage, depending on position of POWER FIXED/VAR switch. Provides a fixed level 20-volts dc B + voltage to other modules.
FREQ DIVIDER FREQ SHIFT switch -----	Selects levels of dc voltage signal to frequency divider module, AN/GRC-106.
10 & 1KC SYNTH SYNTH OUTPUTS AMPL ----- switch.	Controls input to amplifier module AR4.
10 & 1KC SYNTH OUTPUT AMPL switch -----	<p>Pos Action ON Input amplified. OFF Amplifier bypassed.</p>
	<p>Pos Action ON Input amplified. OFF Amplifier bypassed.</p>

Control, indicator, or connector	Function
FREQ STANDARD OUTPUT AMPL switch (2) ----- ----- ----- -----	Controls input to amplifier modules AR1 and AR2. Pos Action ON Input amplified. OFF Amplifier bypassed.
MC SYNTH OUTPUT AMPL switch ----- ----- ----- -----	Controls input to amplifier module AR3. Pos Action ON Input amplified. OFF Amplifier bypassed.
FREQ SELECT 1KC 10KC and controls -----	Controls, mechanically, position of 10-ke and 1-kc shaft couplers.
FREQ SELECT 100KC control -----	Controls, mechanically, position of 100-kc shaft couplers.
POWER ADJ control -----	Controls level of de variable supply voltage.
10&1KC SYNTH SYNTH OUTPUTS VOLTS ADJ----- control.	Controls output level of amplifier AR4.
10&1KC SYNTH OUTPUT VOLT ADJ control -----	Controls output level of amplifier AR5.
FREQ STANDARD OUTPUT VOLT ADJ control ----- (2).	Controls output level of amplifiers AR1 and AR2.
MC SYNTH OUTPUT VOLT ADJ control -----	Controls output level of amplifier AR3.
POWER indicator -----	Indicates POWER switch S1 is set to ON, and +27 volts de is supplied to test tray from test set.
MC SYNTH HI indicator -----	Indicates selection of high band of frequencies.
MC SYNTH LO indicator -----	Indicates selection of low band of frequencies.
J1 -----	Multipin connector for electrical interconnection of tray A3 and test set.
POWER INPUTS FIXED test connector -----	Test point for measurement of fixed +20-volt dc supply.
POWER INPUTS VAR test connector -----	Test point for measurements of variable +20-volt dc supply.
POWER INPUTS (ground) test connector -----	Ground test point for measurement of input voltage.
FREQ STANDARD 5MC EXT/INT connector -----	For connecting test equipment to frequency standard module, RT662/GRC at J7.
FREQ STANDARD OUTPUT 1MC connector -----	For monitoring 1-mc output of frequency standard module, RT-62/GRC.
FREQ STANDARD module connector -----	Multipin connector for electrical interconnection of frequency standard module, RT-662/GRC, and tray A3.
FREQ STANDARD module connector -----	Multipin connector for electrical interconnection of frequency standard module, RT62/GRC, and tray A3.
MC SYNTH module connector -----	Multipin connector for electrical interconnection of me synthesizer module, RT-662/GRC, and tray A3.
FREQ DIVIDER OUTPUTS 100KC SPECTRUM----- connector -----	For monitoring the 100-kc spectrum output of frequency divider module RT-662/GRC.
FREQ DIVIDER OUTPUTS 1.75MC connector -----	For monitoring the 1.75-me output of frequency divider module, RT-462/GRC.
FREQ DIVIDER module connector -----	Multipin connector for electrical interconnection of frequency divider module, RT462/GRC and tray A3.
FREQ DIVIDER module connector -----	Multipin connector for electrical interconnection of frequency divider module, RT-662/GRC, and tray A3.
FREQ DIVIDER OUTPUTS 1KC PULSE ----- connector -----	For monitoring 1-kc pulse output of frequency divider module, RT-662/GRC.
FREQ DIVIDER OUTPUTS 01KC SPECTRUM ----- connector -----	For monitoring 10-kc spectrum output of frequency divider module, RT-662/GRC.
FREQ STANDARD OUTPUT 10MC connector -----	For monitoring 10-me output of frequency standard module, RT-662/GRC.
MC SYNTH OUTPUT MC SYNTH connector -----	For monitoring rf output of me synthesizer module, RT-662/GRC.

Control, indicator, or connector	Function
10&1KC SYNTH SYNTH OUTPUTS 10&1KC ----- connector -----	For monitoring RF output of 10and 1-kc synthesizer module, RT-662/GRC.
TRANSLATOR INPUTS RCVR RF connector -----	For connecting external inputs to translator module, RT-62/GRC.
TRANSLATOR OUTPUTS RCVR IF connector -----	For monitoring translator module, RT-42/GRC, receiver IF output.
100KC SYNTH 100KC SYNTH OUTPUT connector --	For monitoring output of 100-kc synthesizer module, RT-62/GRC.
TRANSLATOR module connector -----	Multipin connector for electrical interconnection of translator module, RT-62/G-RC, and tray A3.
TRANSLATOR module connector -----	Multipin connector for electrical interconnection of translator module, RT662/GRC, and tray A3.
100KC SYNTH module connector -----	Multipin connector for electrical interconnection of translator module, RT462/GRC and tray A3.
TRANSLATOR OUTPUTS XMTR RF connector -----	For monitoring transmitter RF output of translator module, RT-62/GRC at J22.
TRANSLATOR INPUTS XMTR IF connector -----	For connecting external inputs to translator module, RT-62/GRC at J23.
10&1KC SYNTH OUTPUT 7.1MC connector -----	For monitoring 7.1-mc output of 10 and 1-kc synthesizer module, RT-662/GRC.
10&1KC SYNTH module connector -----	Multipin connector for electrical interconnection of 10and 1-kc synthesizer module, RT-622/GRC and tray A3.
10&1KC module connector -----	Multipin connector for electrical interconnection of 10and 1-kc synthesizer module, RT-662/GRC and tray A3.
10&1KC SYNTH INPUTS NOISE BLANK connector --	For connecting external inputs to 10and 1-kc synthesizer module, RT-662/GRC.

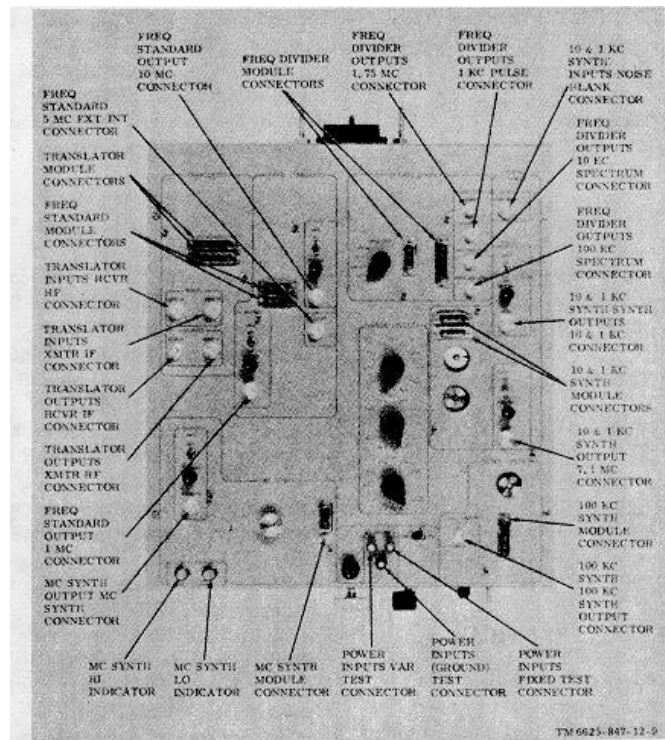

Figure 3-4. (1). Synthesizer test tray A3, controls, indicators, and connectors.

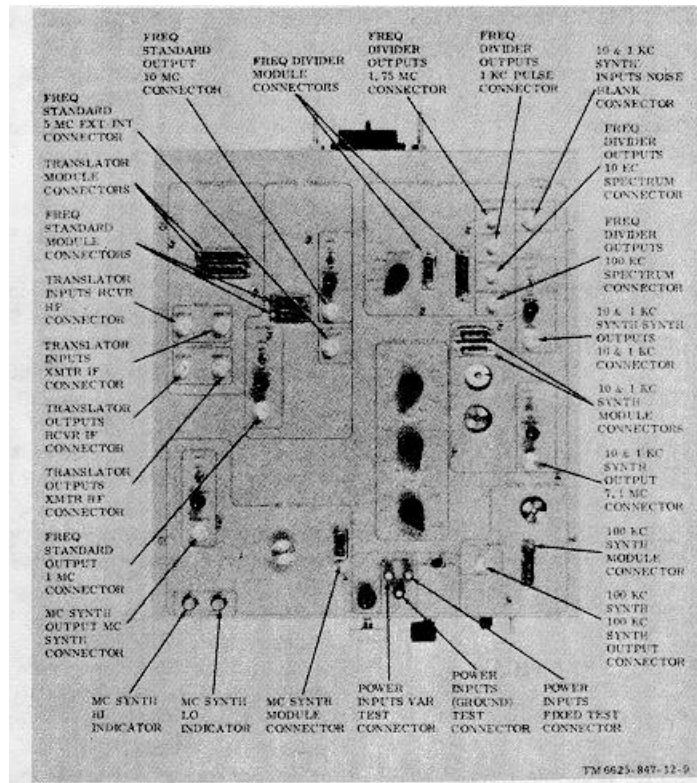

Figure 3-4 (2). — Continued.

3-6. Converter and Control Tray A4, Controls, Indicators, and Connectors
(fig. 3-5 (1) and (2))

Control, indicator, or connector	Function						
POWER switch -----	Controls +27-volt de primary power from test set SERV SEL switch (positions: OVEN ON, STBY, SSB/NSK, FSK, AM and CW) to circuits and connectors on tray A4.						
CONTROL TEST RF BAND-50Ω-WHIP switch -----	Selects pins on connector 33 to be monitored by CONTROL indicators A1 through A5, and B1, B2, and B4.						
	<table border="0"> <thead> <tr> <th data-bbox="779 1323 828 1365">Pos</th> <th data-bbox="828 1323 1266 1365">Action</th> </tr> </thead> <tbody> <tr> <td data-bbox="779 1365 828 1617">RF BAND</td> <td data-bbox="828 1365 1266 1617"> A1 For 2-2-6 μcs. A2 For 253 μcs. A3 For 3344 μcs. A4 For 35-4 μcs. A5 For 4-10 μcs. B1 For 10-22 μcs. B2 For 4-10 μcs. B4 For 10-22 μcs. </td> </tr> <tr> <td data-bbox="779 1617 828 1743">50 (ohm)</td> <td data-bbox="828 1617 1266 1743"> A1 For 2-5 μcs. A2 For 5-7 μcs. A3 For 7-12 μcs. A4 For 12-14 μcs. </td> </tr> </tbody> </table>	Pos	Action	RF BAND	A1 For 2-2-6 μcs. A2 For 253 μcs. A3 For 3344 μcs. A4 For 35-4 μcs. A5 For 4-10 μcs. B1 For 10-22 μcs. B2 For 4-10 μcs. B4 For 10-22 μcs.	50 (ohm)	A1 For 2-5 μcs. A2 For 5-7 μcs. A3 For 7-12 μcs. A4 For 12-14 μcs.
Pos	Action						
RF BAND	A1 For 2-2-6 μcs. A2 For 253 μcs. A3 For 3344 μcs. A4 For 35-4 μcs. A5 For 4-10 μcs. B1 For 10-22 μcs. B2 For 4-10 μcs. B4 For 10-22 μcs.						
50 (ohm)	A1 For 2-5 μcs. A2 For 5-7 μcs. A3 For 7-12 μcs. A4 For 12-14 μcs.						

Control, indicator, or connector	Function	
	Pos	Action
		A5 For 14-19 μ s. B1 For 19-24 μ s. B2 For 24-30 μ s. B4 For 10-22 μ s.
	WHIP	A1 For 10-11 μ s. A2 For 11-12 μ s. A3 For 12-14 μ s. A4 For 27-30 μ s. A5 For 15-24 μ s. B1 (open). B2 For 27-30 μ s. B4 For 10-22 μ s.
CONTROL TEST ANT. MOTOR CONTROL MONITOR switch -----		When set to CAP, connects CONTROL B5 indicator into circuit.
CONTROL TEST ANT. MOTOR CONTROL CODE switch -----		When set to RF BAND, or when set to CAP, grounds the circuit.
PA METER TEST ANT. LOAD-ANT. TUNE switch -----		When set to ANT. LOAD, connects variable dc voltage from ANTENNA LOAD/TUNE control. When set to ANT. TUNE, connects variable dc voltage from ANTENNA LOAD/TUNE control.
INPUT CURRENT switch -----		Permits input current measurement tests of inverter assembly, AM3349/GRC-106
EXTERNAL BLOWER switch -----		When set to HI, increases speed of BLOWER. When set to LO, decreases speed of BLOWER.
TEST SELECTOR switch -----		Controls test points HI and LO voltage measurements of inverter assembly, AM3349/GRC-106.
	Pos	Action
	1	HI---Connected to +27 vdc. LO--Connected to ground.
	2	HI---Connected to test circuit. LO--Connected to EXTERNAL BLOWER.
	3	HI---Connected to test circuit. LO--Connected to test circuit.
	4	HI---Connected to ground. LO--Connected to test circuit.
	5	HI---Connected to INT BLOWER. LO--Connected to inverter.
PA METER TEST ANTENNA LOAD/TUNE control -----		Controls dc voltage level to PA METER TEST ANT. LOAD-ANT. TUNE switch, contact terminal 2.
PA METER TEST ALC METER control -----		Controls dc voltage level to test point.
PA METER TEST GRID DRIVE control -----		Controls dc voltage level to test point.
CONTROL TEST A1 thru A5, and B1, B2, and B4 indicators -----		Indicates ground at pins selected by CONTROL TEST RF BAND-500-WHIP switch.
CONTROL TEST B3 indicator -----		Indicates ground for freq. change.
CONTROL TEST B5 indicator -----		Indicates ground on CONTROL TEST ANT. MOTOR CONTROL MONITOR switch.
CONTROL TEST C1 indicator -----		Indicates +27 volts dc at ANT. MOTOR CONTROL MONITOR switch.
CONTROL TEST C2 indicator -----		Indicates +27 volts dc.
CONTROL TSST C3 indicator -----		Indicates +27 volts dc.
CONTROL TEST C4 indicator -----		-Indicates +27 volts dc.
CONTROL TEST C5 indicator -----		Indicates ground.
POWER indicator -----		Indicates POWER switch is set to ON, and +27 volts dc is supplied to test tray from test set.
J1 -----		Multipin connector for electrical interconnection of tray A4 and test set.

Control, indicator, or connector	Function
PA METER TEST connector -----	Multipin connector for electrical interconnection of front panel assembly, AM-3349/GRC-106, and tray A4.
CONTROL test connector -----	Multipin connector for electrical interconnection of antenna coupler assembly input connector, and tray A4.
PA METER TEST ANTENNA LOAD/TUNE test connector. -----	Test point for measuring antenna load/tune voltage.
PA METER TEST ALC METER test connector-----	Test point for measuring ALC meter voltage.
PA METER TEST (ground) test connector -----	Ground test point for voltage measurements
INPUT CLURRENT HI test connector -----	Test point for input current measurements of dc-to-ac inverter assembly, AM-3349/GRC-106.
INPUT CURRENT LO test connector -----	Test point for input current measurements of dc-to-ac inverter assembly, AM3349/GRC-106.
TEST SELECTOR LO test connector -----	Test point for voltage measurements of dc-to-ac inverter assembly, AM-3349/GRC-106.
TEST SELECTOR HI test connector -----	Test point for voltage measurements of dc-to-ac inverter assembly, AM-3349/GRC-106.
PA METER TEST GRID DRIV.E test connector -----	Test point for measuring grid drive voltage.
Connector -----	Multipin connector for electrical interconnection of dc-to-ac inverter assembly, AM3349/GRC-106.

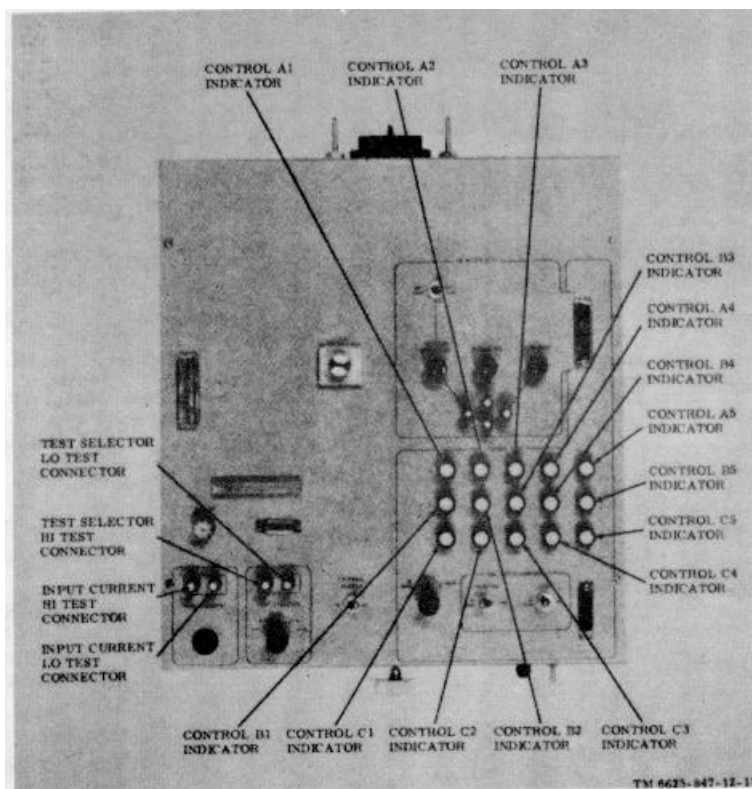

Figure 3-5 (1). Converter and control tray A4, controls, indicators, and connectors.

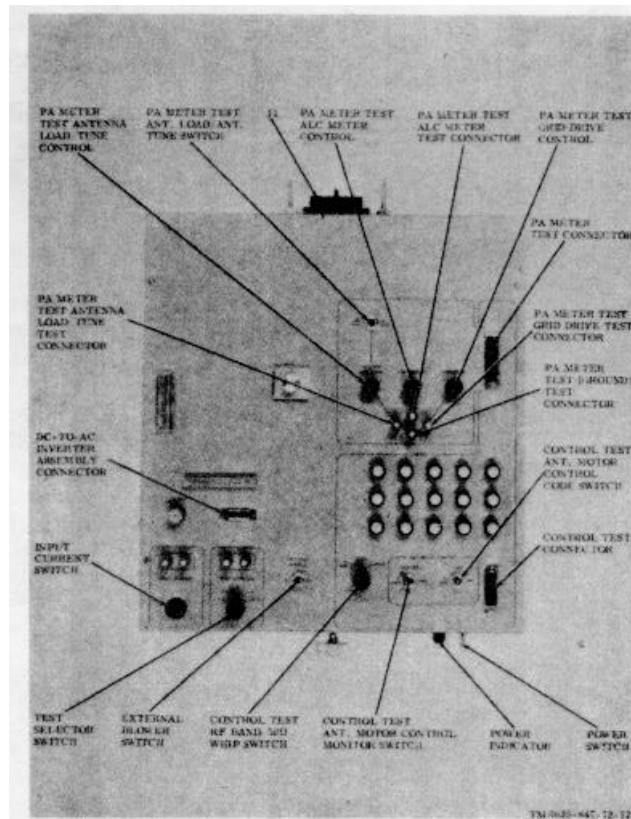

Figure 3-5 (2). — Continued.

3-7. Driver, Discriminator, and Antenna Coupler Tray A5, Controls, indicators and Connectors
(fig. 3-6 (1) and (2))

Control, indicator, or connector	Function																																	
POWER switch -----	Controls +27-volt dc primary power from test set SERV SEL switch (positions: OVEN ON, STBY, SSB/NSK, FSK, AM and CW) to circuits and controls of tray A5.																																	
DRIVER TEST switch -----	Controls DRIVER test points HI and LO for voltage measurements of driver assembly, AM3349/ GRC-106.																																	
	<table border="0"> <tr> <td data-bbox="782 1348 841 1375">Pos</td> <td data-bbox="841 1348 1547 1375"></td> <td data-bbox="1291 1348 1380 1375">Action</td> </tr> <tr> <td data-bbox="782 1375 841 1402">1</td> <td data-bbox="841 1375 1547 1402">HI --- Connected for 6.3 v ac.</td> <td data-bbox="1291 1375 1547 1402"></td> </tr> <tr> <td data-bbox="782 1402 841 1430"></td> <td data-bbox="841 1402 1547 1430">LO -- Connected to ground.</td> <td data-bbox="1291 1402 1547 1430"></td> </tr> <tr> <td data-bbox="782 1430 841 1457">2</td> <td data-bbox="841 1430 1547 1457">HI -- Connected for +200 v dc.</td> <td data-bbox="1291 1430 1547 1457"></td> </tr> <tr> <td data-bbox="782 1457 841 1484"></td> <td data-bbox="841 1457 1547 1484">LO -- Connected to ground.</td> <td data-bbox="1291 1457 1547 1484"></td> </tr> <tr> <td data-bbox="782 1484 841 1512">3</td> <td data-bbox="841 1484 1547 1512">HI -- Connected to meter.</td> <td data-bbox="1291 1484 1547 1512"></td> </tr> <tr> <td data-bbox="782 1512 841 1539"></td> <td data-bbox="841 1512 1547 1539">LO -- Connected to ground.</td> <td data-bbox="1291 1512 1547 1539"></td> </tr> <tr> <td data-bbox="782 1539 841 1566">4</td> <td data-bbox="841 1539 1547 1566">HI -- Connected for +27 v dc.</td> <td data-bbox="1291 1539 1547 1566"></td> </tr> <tr> <td data-bbox="782 1566 841 1593"></td> <td data-bbox="841 1566 1547 1593">LO -- Connected to ground..</td> <td data-bbox="1291 1566 1547 1593"></td> </tr> <tr> <td data-bbox="782 1593 841 1621">5</td> <td data-bbox="841 1593 1547 1621">HI -- Connected to +200 v dc.</td> <td data-bbox="1291 1593 1547 1621"></td> </tr> <tr> <td data-bbox="782 1621 841 1648"></td> <td data-bbox="841 1621 1547 1648">LO -- Connected to +200 v dc.</td> <td data-bbox="1291 1621 1547 1648"></td> </tr> </table>	Pos		Action	1	HI --- Connected for 6.3 v ac.			LO -- Connected to ground.		2	HI -- Connected for +200 v dc.			LO -- Connected to ground.		3	HI -- Connected to meter.			LO -- Connected to ground.		4	HI -- Connected for +27 v dc.			LO -- Connected to ground..		5	HI -- Connected to +200 v dc.			LO -- Connected to +200 v dc.	
Pos		Action																																
1	HI --- Connected for 6.3 v ac.																																	
	LO -- Connected to ground.																																	
2	HI -- Connected for +200 v dc.																																	
	LO -- Connected to ground.																																	
3	HI -- Connected to meter.																																	
	LO -- Connected to ground.																																	
4	HI -- Connected for +27 v dc.																																	
	LO -- Connected to ground..																																	
5	HI -- Connected to +200 v dc.																																	
	LO -- Connected to +200 v dc.																																	
DISCRIMINATOR TEST SELECTOR switch -----	Controls DISCRIMINATOR test points HI and LO for voltage measurements of the discriminator assembly, AM-3349/GRC-106.																																	

Control, indicator, or connector	Function	
	Pos	Action
RELAY RELAY CONTROL switch -----	1 HI -- Connected to test circuit. LO -- Connected to test circuit. 2 HI --- Connected to test circuit. LO -- Connected to test circuit. 3 HI --- Connected to ground. LO -- Connected to test circuit.	Grounds various pins on connector J10.
	Pos	Action
ANTENNA COUPLER CODE switch -----	1 (Open) 2 Circuit grounded. 3 Circuit grounded. 4 Circuit grounded. 5 Circuit grounded.	Selects correct load condition for testing at frequencies of 2 me to 30 me. Controls motor for physical position of antenna coupler inductor and capacitor tuning shafts on antenna coupler assembly, AM-3349/GRCA-06.
ANTENNA COUPLER 50n DUMMY LOAD COUPLER TERMINATION WHIP-50Ω DOUBLET switch.		Selects antenna coupler load for the antenna coupler assembly, AM-349/GRC-106.
POWER indicator -----		Indicates POWER switch is set to ON, and +27 volts dc is supplied to test tray from test set.
DRIVER 200 VDC indicator		Indicates +200 volts dc supplied to test tray from test set.
ANTENNA COUPLER CAP. MOTOR indicator		Indicates correct ground, and +27 volts dc is at pin 14 present.
ANTENNA COUPLER BAND SW MOTOR indicator.		Indicates correct ground, and +27 volts dc is present.
RELAY 1 indicator-----		Indicates +27 volts dc is present.
RELAY 2 indicator -----		Indicates correct ground.
RELAY 3 indicator -----		Indicates +27 volts dc is present.
RELAY 4 indicator -----		Indicates +27 volts dc is present.
RELAY 5 indicator -----		Indicates +27 volts dc is present.
RELAY 6 indicator -----		Indicates +27 volts de is present.
RELAY 7 indicator-----		Indicates correct ground
DRIVER BAND SEL switch -----		Mechanically selects load transformers for driver assembly, AM-3349/GRC-106.
FEEDBACK IN connector -----		For connecting external feedback voltage to driver assembly under test.
RF IN connector -----		For connecting external RF signals to driver assembly under test.
RF OUT connector -----		For connecting test equipment to monitor RF within driver assembly under test.
J1 -----		Multipin connector for electrical interconnection of tray A5, and test set.
DISCRIMINATOR RF IN connector -----		For connecting external signals to discriminator assembly AM-3349/GRC-106.
DISCRIMINATOR assembly connector -----		Multipin connector for electrical interconnection of discriminator assembly AM-3349/GRC-106, and tray A5.
DRIVER HI test connector -----		Test point for voltage measurements of driver assembly AM349/GRC-106.
DRIVER LO test connector -----		Test point for voltage measurements of driver assembly AM-349/GRC-106.
DISCRIMINATOR HI test connector -----		Test point for voltage measurements of discriminator assembly AM-349/GRC-106.

Control, indicator, or connector	Function
DISCRIMINATOR LO test connector -----	Test point for voltage measurements of discriminator assembly AM4349/GRC-106.
DISCRIMINATOR connector -----	For connecting DISCRIMINATOR RF IN connector to discriminator assembly AM3349/GRC-106.
DISCRIMINATOR ALC OUT test connector -----	For monitoring the ALC output of the discriminator assembly AM-3349/GRC-106.
RELAY assembly connector -----	Multipin connector for electrical interconnection of relay assembly AM-349/GRC-106, and tray AS.
ANTENNA COUPLER assembly connector-----	Multipin connector for electrical interconnection of antenna coupler assembly AM-349/GRC-106, and tray AS.

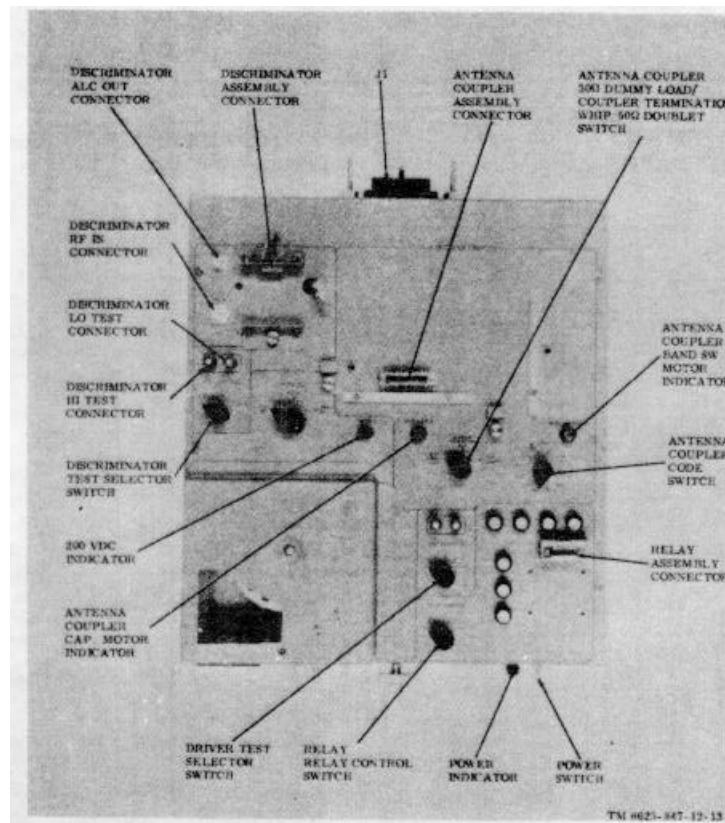

Figure 3-6 (1). Driver, discriminator, and antenna coupler tray A5, controls, indicators, and connectors.

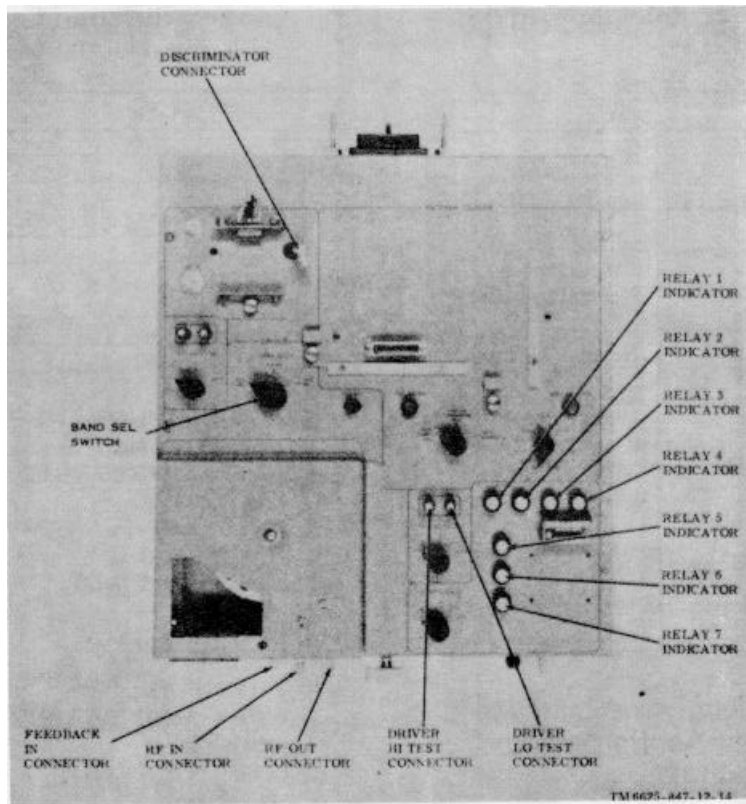

Figure 3-6 (2). — Continued.

Section II. OPERATIONAL INSTRUCTIONS

3-8. General

This section provides turn-on, normal operation, and shutdown procedures for the 2A/GRC.

3-9. Charts

The charts given in paragraphs 3-10 through 3-15 provide the operator with a fast, convenient, and safe method of equipment turn-on; paragraph 3-10 covers the preliminary switch and control settings for the test set, and paragraphs 3-11 through 3-16 cover the individual test trays used with the test set.

3-10. Test Set, Preliminary Switch and Control Settings

(fig. 3-1 (1) and (2))

Switch or control	Setting
POWER switch -----	OFF.
SERV SEL switch	OFF.

Switch or control	Setting
PA/RT switch-----	PA.
KEY switch -----	OFF.
XMIT STATUS switch-----	OPR.
REC-XMIT switch-----	REC.
ALC VOLTAGE INFO----- control. -----	Fully counterclock- wise.
ALC VOLTAGE TUNE----- control. -----	Fully counterclock- wise.
IF OSCILLATOR select ----- Switch	4.
MC FREQ 10MC switch-----	0.
MC FREQ 1MC switch -----	0.
MC FREQ .1MC switch-----	0.
500 VDC LOAD switch -----	LOW.
2400 VDC LOAD switch-----	1.

3-11. Common Module Tray, A1 Preliminary Switch and Control Settings

(fig. 3-2 (1) and (2))

Switch or control	Setting
POWER switch -----	OFF.
DC/DC CONVERTER:	
LOAD SELECT switch ----	100.
TEST SELECTOR ----- switch.	1.
CONV/REC TEST CONV - switch (momentary).	Normal relaxed.
CONV/REG TEST REG --- switch (momentary).	Normal relaxed.
RF AMPL:	
100 KC SELECTOR ----- switch	0.
10 KC SELECTOR ----- switch.	0.
AGC ON-OFF switch -----	OFF.
AGC ADJ control -----	Fully counterclock- wise

3-12. Common Module Tray A2, Preliminary Switch and Control Settings

(fig. 3-3 (1) and (2))

Switch or control	Setting
POWER switch-----	OFF.
RCVR AUDIO:	
SQUELCH switch-----	OFF.
SQUELCH SYNC switch---	OFF.
AUDIO GAIN control-----	Fully counterclock- wise.
RCVR IF:	
AGC SYNC switch -----	OFF.
RF AGC ON-OFF switch --	OFF.
TEST SELECTOR ----- switch.	1.
BFO TONE control -----	Fully counterclock- wise
RF GAIN control -----	Fully counterclock- wise
XMTR IF AND AUDIO:	
ALC APC PPC CONTROL ALC switch.	OFF.
ALC APC PPC CONTROL APC/PPC SEL switch.	OFF.
ALC APC PPC CONTROL POWER CONTROL.-----	Fully counterclock- wise.
VOICE MODES switch-----	PUSH TO TALK.
TEST SELECTOR switch -	1.

3-13. Synthesizer Test Tray A3, Preliminary Switch and Control Settings

(fig. 3-4 (1) and (2))

Switch or control	Setting
POWER switch_ -----	OFF.
MODULE SELECT switch	10&1KC.
POWER:	
VAR-FIXED switch -----	FIXED.
ADJ control -----	Midrange
FREQ SELECT:	
10KC control -----	0.
1 KC control -----	0.
100KC control-----	0.
10&1KC SYNTH:	
SYNTH OUTPUTS AMPL - ON-OFF switch	OFF.
SYNTH OUTPUTS VOLT - ADJ control	Midrange
OUTPUT AMPL ON-OFF-- switch.	OFF.
OUTPUT VOLT ADJ ----- control	Midrange
FREQ DIVIDER FREQ----- SHIFT switch.	OFF.
FREQ STANDARD:	
OUTPUT AMPL ON-OFF-- switch (2).	OFF.
OUTPUT VOLT ADJ ----- control (2).	Midrange.
MC SYNTH section:	
OUTPUT AMPL ON-OFF .. switch.	OFF.
OUTPUT VOLT ADJ ----- control.	Midrange

3-14. Converter and Control Tray AA, Preliminary Switch and Control Settings

(fig. 3-4 (1) and (2))

Switch or control	Setting
POWER switch-----	OFF.
INPUT CURRENT switch-----	Normally relaxed.
TEST SELECTOR switch-----	1.
PA METER TEST:	
ANT. LOAD-ANT. TUNE . switch.	ANT. TUNE.
ANTENNA LOAD/TUNE --- control.	Midrange
ALC METER control -----	Fully counter- clockwise.
GRID DRIVE control -----	Fully counter- clockwise.
CONTROL TEST:	
ANT. MOTOR CONTROL MONITOR switch.	RF BAND.

Swatch or control	Setting
ANT. MOTOR CONTROL CODE switch	Normally relaxed.
RF BAND -50Ω-WHIP switch.	RF BAND.

3-15. Driver, Discriminator, and Antenna Coupler Tray A5, Preliminary Switch and Control Settings
(fig. 3-6 (1) and (2))

Switch or control	Setting
POWER switch-----	OFF.
RELAY RELAY CONTROL switch.	1.
ANTENNA COUPLER: CODE switch -----	1.
50Ω DUMMY LOAD COUPLER TERMINATION WHIP-50Ω DOUBLET switch.	50Ω DUMMY LOAD.
DISCRIMINATOR TEST SELECTOR switch.	1.
DRIVER: BAND SEL switch -----	3.25 MC.
TEST SELECTOR 1. switch.	

3-16. Starting Procedures

Apply power to the test set as follows:

- a. Set the switches and the controls located on the test set to the settings listed in paragraph 3-10.

Note. If the AN/GRC-106 modules test is to be done, perform the procedures given in e below. For a system test, perform the procedures given in b below.

- b. Connect the equipment to be tested to the test set with the appropriate test cables as shown in figures 1-1 and 4-1.

- c. Set the test set POWER switch ON; POWER indicator should light.

- d. On the test set, connect the dc test leads of Multimeter AN/PSM-6 (AN/PSM-6) between DC VOLTAGE test points +20 and ground. Rotate the SERV SEL switch to OVEN ON, and adjust the DC VOLTAGE 20 control for a +20volt de indication on the multimeter.

- e. To test the AN/GRC-106 modules, connect and secure the appropriate test tray to the test set with the connector holddown screw on the front panel of the module test tray, as TM 11-6625-847-12 shown in figure 3-8. Refer to paragraph 1-5 for a cross-reference of AN/GRC-106 modules testable by the test set test trays.

- f. On the test tray being used, set the switches and the controls to the settings listed in the appropriate paragraph (para 3-11 through 3-15).

- g. Set the test set POWER switch to ON; POWER indicator should light.

- h. On the test set, connect the AN/PSM-6 dc test leads between DC VOLTAGE test points +20 and ground. Adjust the DC VOLTAGE 20 control for +20-volt dc indication on the AN/PSM-6.

Note. If tray A5 is connected to the test set, perform the procedures given in i below.

- i. On the test set, connect the AN/PSM-6 dc test leads between DC VOLTAGE test points +200 and ground. Adjust the DC VOLTAGE 200 control for +200-volt dc indication on the AN/PSM-6.

3-17. Preparation for System Test Operation

Prepare for the AN/GRC-106 system test with the test set as follows:

- a. Perform the procedures given in paragraph 3-16e through h and, if necessary, the procedures given in paragraph 3-16i.

- b. Rotate the SERV SEL switch to STBY; allow 15 minutes for warmup.

3-18. Preparation for Module Test Operation

Prepare to test the AN/GRC-106 modules with the test set as follows:

- a. Perform the procedures given in paragraph 3-17b, c, and d and, if necessary, the procedures given in paragraph 3-16i.

- b. Rotate the SERV SEL switch to STBY.
- c. Set the test tray POWER switch to ON.

3-19. Stopping Procedures

Shutdown the test set after use as follows:

- a. Set the SERV SEL switch to OFF.
- b. Set the test set POWER switch to OFF.

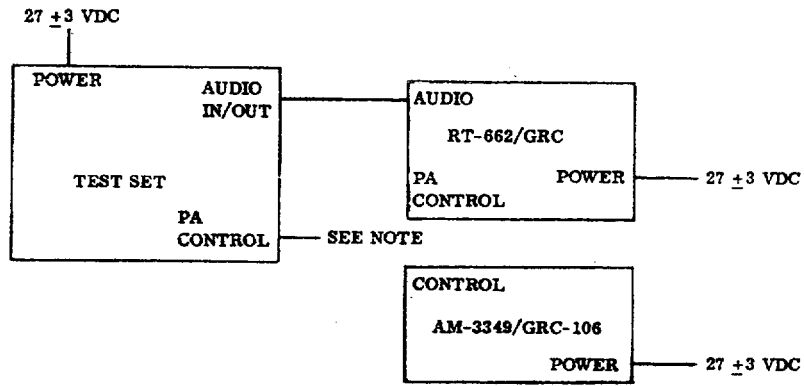

NOTE

PA CONTROL CABLE IS NOT REQUIRED WHEN TESTING THE RT-662/GRC AND AM-3349/GRC-106 UNITS AS A SYSTEM, WHEN TESTING THE UNITS SEPARATELY THE PA CONTROL CABLE IS CONNECTED TO THE UNIT BEING TESTED.

TM 6625-847-12-15

Figure 3-7. SM-442A/GRC, system test

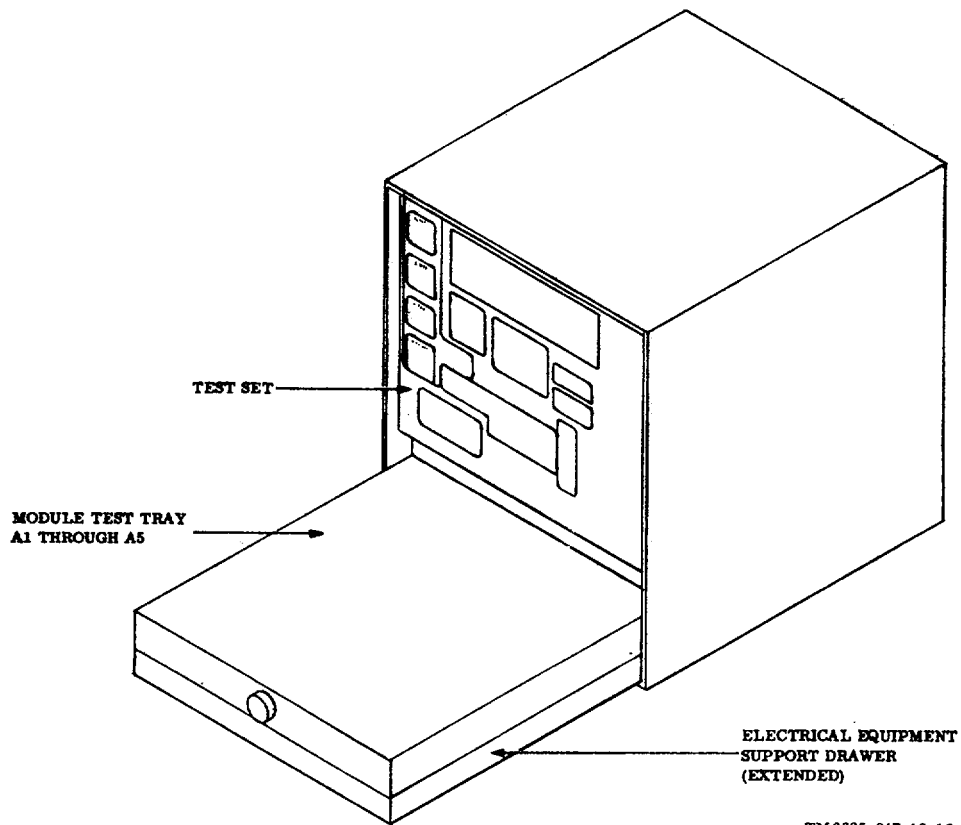

TM 6625-847-12-16

Figure 3-8. Test set with a tray mounted.

**CHAPTER 4
OPERATOR AND ORGANIZATIONAL MAINTENANCE**

Section I. OPERATOR'S MAINTENANCE

4-1. Scope of Operator's Maintenance

The maintenance duties assigned to the operator of the SM-442A/GRC are listed below, together with a reference to the paragraphs which cover the specific maintenance function.

- a. Operators daily preventive maintenance checks and services chart (para 4-4).
- b. Cleaning (para 4-5).

4-2. Materials Required

- a. Cleaning Compound (Federal stock No. 7930-395-9542).
- b. Cleaning cloth (lint-free).
- c. Fine sandpaper.

4-3. Operator's Preventive Maintenance

Operator's preventive maintenance is the systematic care, servicing, and inspection of equipment to prevent the occurrence of trouble, reduce downtime, and assure that the equipment is serviceable.

a. *Systematic Care.* The procedures given in paragraphs 4-4 and 4-5 cover routine systematic care and cleaning essential for proper equipment operation and maintenance.

b. *Preventive Maintenance Checks and Services.* The preventive maintenance checks and services chart (para 4-4) outlines functions to be performed at specific

intervals. These checks and services are to maintain Army electronic equipment in combat-serviceable condition; that is, in good general (physical) condition and in good operating condition. To assist operators in maintaining combat serviceability, the chart indicates what to check, how to check, and the normal conditions; the references column lists the paragraphs that contain detailed repair or replacement procedures. Where no entry exists in the reference column, the defect cannot be remedied by the operator; therefore, higher category of maintenance or repair is required. Records and reports of these checks and services must be made in accordance with the requirements set forth in TM 38-750.

c. *Preventive Maintenance Checks and Services Periods.* Preventive maintenance checks and services of the SM-442A/GRC are required daily. Paragraph 4-4 specifies checks and services that must be accomplished daily and under the special conditions listed in (1), (2), and (3) below:

- (1) When the equipment is initially installed.
- (2) When the equipment is reinstalled after removal for any reason.
- (3) At least once each week if the equipment is maintained in a standby condition.

4-4. Operator's Daily Preventive Maintenance Checks and Services Chart

Sequence No.	Item to be Inspected	Procedures	References
1	Exterior surfaces-----	Clean exterior surfaces of units which comprise SM-442A/GRC.	Para 4-5.
2	Intercabling and connectors	Check all interconnecting cables and connectors for cracks and breaks. Replace cables that have cracks or broken connectors.	Fig. 1-1.

Sequence No.	Item to be Inspected	Procedures	References
3	Fuses -----	Check fuses for correct value. Check spares for quantity and proper values.	Fig. 3-1.
4	Knobs, controls and switches	Check to be sure that mechanical action of all knobs, controls, and switches is smooth and free from external or internal binding.	Fig. 3-1 through 3-6.
5	Completeness -----	Check to see that SM-442A/GRC is complete.	App B.
6	Indicator lamps-----	Check indicator lamps for correct value. Check spares for quantity and proper values.	App B.

4-5. Cleaning

Inspect the exterior of the SM-442A/GRC; exterior surfaces must be free of dust, dirt, grease, and fungus.

a. Remove dust and loose dirt with a clean, soft cloth.

Warning: Prolonged breathing of cleaning compound is dangerous; make sure adequate ventilation is provided. Cleaning compound is flammable; do not use near a flame. Avoid contact with the skin; wash off any that spills on the hands.

b. Remove grease, fungus, and ground-in dirt from the case being cleaned; use a cloth dampened (not wet) with the cleaning compound.

c. Remove dust or dirt from the connectors with a brush.

d. Clean the front panel and the control knob; use a soft, clean cloth. If dirt is difficult to remove, dampen the cloth with water; use mild soap if necessary.

Section II. ORGANIZATIONAL MAINTENANCE

4-6. Scope of Organizational Maintenance

This section contains instructions covering organizational maintenance of the SM-442A/ GRC. It includes instructions for performing preventive and periodic maintenance services and repair functions to be accomplished by the organizational repairman as follows:

- a. Organizational preventive maintenance (para 4-8).
- b. Organizational quarterly preventive maintenance (para 4-9).
- c. Organizational quarterly preventive maintenance checks and services chart (para 4-10).
- d. Preservation (para 4-11).
- e. Lubrication (para 4-12).
- f. Troubleshooting (para 4-13 through 4-25).
- g. Replacement and adjustment (para 4-26).

- c. Counter, Electronic, Digital Readout AN/ USM-207.
- d. Generator, Signal AN/URM-127.
- e. Oscilloscope AN/USM-140.
- f. Power Supply PP-3940/G.
- g. Multimeter ME-26A/U, ME-26B/U, or ME-26C/U.

4-7. Test Equipment Required

The test equipment required for organizational maintenance is as follows:

- a. Multimeter AN/PSM-6.
- b. Voltmeter, Electronic AN/URM-145.

4-8. Organizational Preventive Maintenance

a. Organizational preventive maintenance is the systematic care and inspection of equipment to maintain it in serviceable condition, prevent breakdowns, and assure maximum operational capability. Preventive maintenance is the responsibility of all categories concerned with the equipment. It includes inspection, testing, and repair or replacement of parts that inspections and tests indicate would probably fail before the next scheduled periodic service. Preventive maintenance checks and services of the SM-442A/GRC at the organizational category are made at quarterly interval, unless otherwise directed by the commanding officer.

b. Maintenance forms and records to be used and maintained on this equipment are specified in TM 38750.

Daily services constitute a part of the quarterly preventive maintenance checks and services and must be concurrently performed. All deficiencies will be recorded in accordance with the requirements of TM 38-750. Perform all the checks and services in the sequence listed in paragraph 4-10.

4-9. Organizational Quarterly Preventive Maintenance

Quarterly preventive maintenance checks and services on the SM-442A/GRC are required.

4-10. Organizational Quarterly Preventive Maintenance Checks and Services Chart

Sequence No.	Item to be Inspected	Procedures	References
1	Publications -----	Check to see that the publications are complete, serviceable, and current.	DA Pam 310-4.
2	Modification -----	Check DA Pam 310-4 to determine if new applicable MWO's must be applied immediately. All NORMAL MWO's must be scheduled.	DA Pam 310-4.
3	Spare parts ----- .	Check all spare parts, operator and organizational, for general condition and method of storage. Overstock should not be evident, and all shortages must be on valid requisitions	App B.
4	Cables and connectors.	Check cable connectors, mating plugs, and jacks of SM-42A/GRC to be sure they are clean, intact, and corrosion free. Inspect cables for chafed, cracked, or frayed insulation. Repair minor damage to insulation with rubber tape and friction tape.	Fig. 1-1.
5	Handles and latches.---	Check handles, latches, and hinges for loose ness; tighten or replace, as necessary.	Fig. 1-1.
6	Metal surfaces. -----	Inspect painted surfaces for spots, rust, and corrosion. Clean and touchup paint as required.	Para 4-11.
7	Operational check ----- .	Check the equipment by performing operational procedures.	Para 3-16 through 3-19.

4-11. Preservation

Remove rust and corroiosn from metal surfaces by lightly sanding them with fine sandpaper. Brush two thin coats of paint on the bare metal to protect it from further corrosion. Refer to applicable cleaning and refinishing practices specified in TB SIG 291 and TB SIG 364.

4-12. Lubrication

The SM-442A/GRC does not require lubrication at regular intervals since there is very little mechanical load on either the drive gears or the drive chains. The blower motor is a sealed unit and cannot be lubricated.

Section III. ORGANIZATIONAL TROUBLESHOOTING

4-13. General

Note. Troubleshooting is not performed by the operator.

Troubleshooting the SM-442A/GRC by the organizational repairman is based on localization and isolation procedures contained in the trouble localization and isolation charts. To troubleshoot the equipment,

perform all the functions starting with paragraph 4-14 and proceed through the items of the trouble localization chart, until an abnormal condition or result is observed. When a abnormal condition or result is observed, perform the checks and corrective actions indicated in the trouble isolation chart. If the corrective measures in

icated do not result in correction of the trouble, a higher category of maintenance is required. Paragraph 4-26 contains additional information and instructions to be used during the replacement and adjustment procedures.

4-14. Test Set, Trouble Localization Chart

The chart below specifies the performance required to be sure that the test set is operational.

Step No.	Operation of test equipment	Control setting and operation of equipment	Performance standard and references
1	Be sure that ± 27 -dc primary power is supplied to test set POWER connector.	Set switches and controls on test set to setting listed in paragraph 3-10. Set POWER switch to ON-----	POWER indicator illuminates (para 4-15, item No. 1).
3	Refer to figure 4-1 for test equipment; energize the equipment and allow X 30 minutes for warmup. Connect AN/PSM-6 dc test leads to DC VOLT-AGE test points +20 and (ground).	Rotate SERV SEL switch to OVEN ON. Adjust DC VOLT-AGE 20 control for +20-volt indication on AN/PSM-6.	
4	Use AN/USM-207 to measure frequency at IF OSCILLATOR 1 1.75 MC OUT connector.	Adjust IF OSCILLATOR 1 1.75 MC output level control for an indication on AN/USM-207 counter.	1.750000 mc + 100 cps (para 4-15, item No. 2).
5	Disconnect AN/USM-207 from IF OSCILLATOR 1 1.75 MC OUT connector and connect ANI URM-145.	Rotate IF OSCILLATOR 1 1.75 MC output level control from fully counterclockwise to fully clockwise.	Output rf level should vary from 0 to (at least) +300 mv (para 4-15, item No. 3).
6	Use AN/USM-207 to measure frequency at IF OSCILLATOR 2 1.7515 MC OUT connector.	Adjust IF OSCILLATOR 2 1.7515 MC output level control for an indication on AN/USM-207.	1.751500 mc \pm 100 cps (para 4-15, item No. 4).
7	Disconnect AN/USM -297 from IF OSCILLATOR 2 1.7515 MC OUT connector and connect AN/ URM-145.	Rotate IF OSCILLATOR 2 1.7515 MC output level control from fully counterclockwise to fully clockwise.	Output rf level should vary from 0 to (at least) 300 mv (para 4-15, item No. 5).
8	Use AN/USM-207 to measure frequency at IF OSCILLATOR 3 1.7525 MC OUT connector.	Adjust IF OSCILLATOR 3 1.7502 MC output level control for an indication on AN/USM-207.	1.752500 mc \pm 100 cps (para 4-15, item No. 6).
9	Disconnect AN,U,SM--207 from IF OSCILLATOR 3 1.7525 MC OUT connector and connect AN/ URM-145.	Rotate IF OSCILLATOR 3 1.7525 MC output level control from fully counterclockwise to fully clockwise.	Output rf level should vary from 0 to (at least) 300 mv (para 4-15, item No. 7).
10	Set AN,TRM-127 to 5%(h cps at 5-volt amplitude. Connect output of AN/ URM-127 to PULSE GENERATOR INPUT connector. Connect AN/ USM-140 to PULSE GENERATOR OUTPUTS 3 connector.	Adjust PULSE GENERATOR (lower) WIDTH and AMPLITUDE controls for a 1-usec, 1-volt positive pulse indication.	Para 4-15, No. 8.

Stop No.	Operation of test equipment	Control setting and operation of equipment	Performance standard and references
11	Connect AN/USM-140 to PULSE GENERATOR OUTPUTS 2 connector.	Adjust PULSE GENERATOR (upper) WIDTH and AMPLITUDE controls for a 150-usec, 1 volt negative pulse indication.	Para 4-15, item No. 6.
12	Connect AN/USM-140 to PULSE GENERATOR OUTPUTS 1 connector.	Adjust PULSE GENERATOR (upper) WIDTH and AMPLITUDE controls for 86 1 volt positive pulse indication.	Para 4-15, item No. 10. usec,
13	Connect AN/PSM-6 dc test leads between ALC VOLTAGE TUNE OUT test connector and ground.	Rotate SERV SEL switch to SSB/NSK. Adjust ALC VOLT AGE TUNE control from fully counterclockwise to fully clock wise.	Output voltage should vary from 0 to 20 volts dc (para 4-15, item No. 11).
14	Connect AN/PSM- d& test leads between ALC VOLTAGE INFO OUT test connector and ground.	Rotate SERV SEL switch to SSB/NSK. Rotate ALC VOLT AGE INFO control from fully counterclockwise to fully clock wise.	Output voltage should vary from 0 to 20 volts dc (para 4-15, item No. 12).
15	Disconnect all test equipment.	Reset all switches and controls to settings given in paragraph 3-10.	POWER indicator extinguishes.

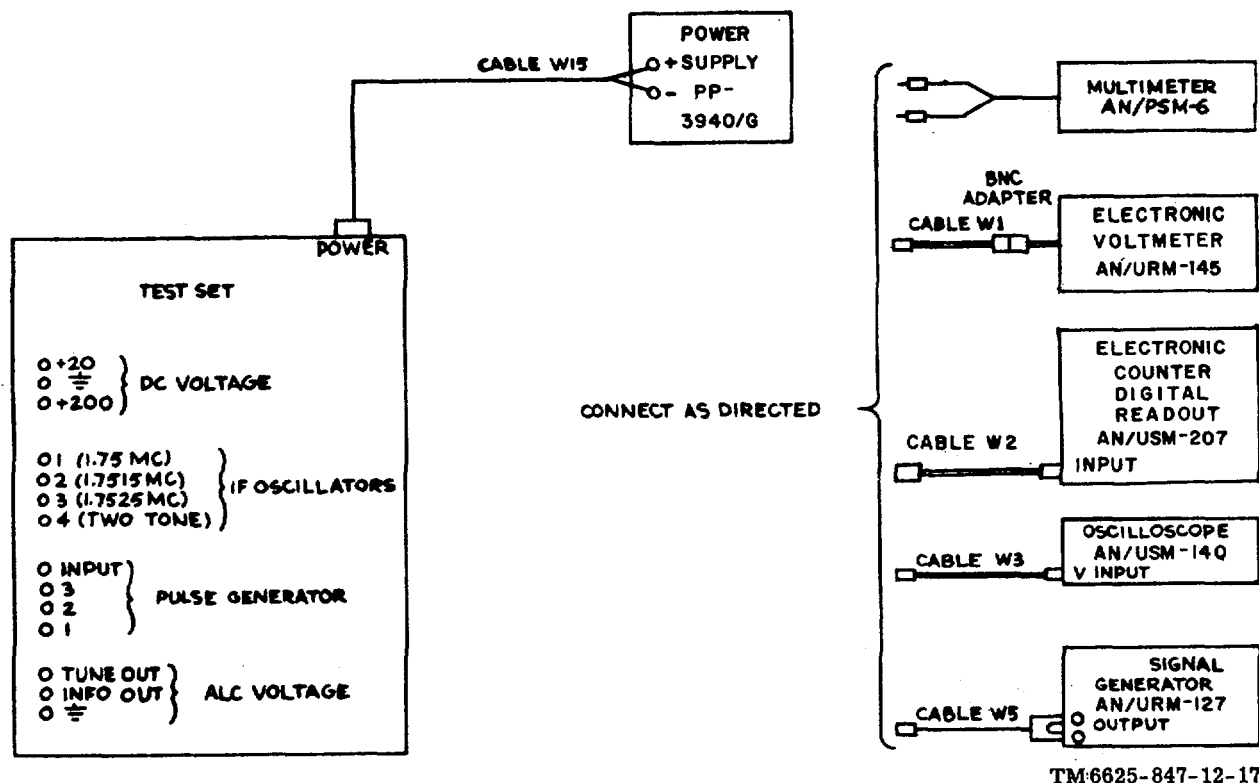

Figure 4-1. Test equipment for trouble localization in SM-442A/GRC.

4-15. Test Set, Trouble Isolation Chart

Item No.	Trouble symptom	Probable trouble	Checks and corrective measures
1	POWER indicator will not illuminate.	a. Defective external 28-volt dc power supply. b. Improper seating of input power connector. c. Defective fuse----- d. Defective indicator light ----- e. Defective POWER switch-----	a. Higher category repair required. b. Tighten power connector. e. Replace fuse. d. Replace indicator light. "-/ e. Higher category repair required.
2	Adjustment of IF OSCILLATOR 11.75 MC output level control fails to produce correct frequency indication.	a. Defective switch----- b. Defective IF OSCILLATOR control.	a. Higher category repair required. b. Higher category repair required.
3	Rotating IF OSCILLATOR 11.75 MC output level control does not vary output rf level from 0 to 300 mv; however, correct frequency indication is present.	a. Defective IF OSCILLATOR control. b. Defective oscillator assembly.	a. Higher category repair required. b. Higher category repair required.
4	Adjustment of IF OSCILLATOR 2 1.75,15 MC output level control fails to produce correct frequency indication.	a. Defective switch----- b. Defective IF OSCILLATOR control. c. Defective oscillator assembly.	a. Higher category repair required. b. Higher category repair required. c. Higher category repair required.
5	Rotating IF OSCILLATOR 2 1.7515 MC output level control does not vary rf output level from 0 to 300 mv; however, correct frequency indication is obtainable.	Defective oscillator -----	Higher category repair required.
6	Adjustment of IF OSCILLATOR 3 1.7525 MC output level control fails to produce correct frequency indication.	a. Defective switch----- b. Defective IF OSCILLATOR control. c. Defective oscillator assembly.	a. Higher category repair required. b. Higher category repair required. c. Higher category repair required.
7	Rotating IF OSCILLATOR 3 1.7525 MC output level control does not vary rf output level from 0 to 300 mv; however, correct frequency indication is obtainable.	a. Defective IF OSCILLATOR control. b. Defective oscillator assembly.	a. Higher category repair required. b. Higher category repair required.
8	Correct signal not obtainable at PULSE GENERATOR OUTPUTS 3 connector. quired.	a. Broken or improperly seated connector. b. Defective pulse generator-----	a. Higher category repair required. b. Higher category repair re-
9	Correct signal not obtainable at PULSE GENERATOR OUTPUTS 2 connector.	Same as 8 above -----	Same as 8 above.
10	Correct signal not obtainable at PULSE GENERATOR OUTPUTS 1 connector.	Same as 8 above -----	Same as 8 above.

Item No.	Trouble symptom	Probable trouble	Checks and corrective measures
11	Adjustment of ALC VOLTAGE TUNE control	Defective SERV SEL switch -----	Higher category repair required.
12	Adjustment of ALC VOLTAGE. INFO control does not vary output voltage from 0 to 22 volts de.	Defective SERV SEL switch -----	Higher category repair required

4-16. Common Module Tray A1, Trouble Localization Chart

The chart below specifies the performance required to be sure that tray A1 is operational.

Step No.	Oration of test equipment	Control setting and operation of equipment	Performance standard and references
1	<i>Note.</i> AN/PSM-6 is only piece of test equipment required for following test. Remove tray A1 from storage case and secure it to the test set.		
2	Insure that +27-volt de primary power is supplied to POWER connector on test set.	Set switches and controls on test set to positions listed in paragraph 3-10. Set switches and controls on tray A1 to settings listed in paragraph 3-11.	
3	Rotate SERV SEL switch to SSB/NSK.	Set test set POWER switch to ON. Set tray A1 POWER switch to ON.	Test set POWER indicator illuminates (para 4-17, item No. 1).
4	Measure dc voltage at DC/DC LOAD SELECT CONVERTER test connectors between HI (+) and LOW (-) with AN/PSM-6.		+27 ± 1 volts dc; tray A1 POWER indicator illuminates (para 4-17, item No. 2).
5	Connect de test leads of AN/PSM-6 to RF AMPL AGC test connectors TEST (-) and (ground (+)).	Set AGC OFF/ON switch to ON. Rotate RF AMPL AGC ADJ control from fully counterclockwise to fully clockwise	Measured voltage should vary from 0 to 28 volts de (para 4-17, item No. 4).
6	Measure de voltage at NOISE BLANKER NOISE BLANKER 20 VDC test connector with AN/PSM-6.		+20 ± 1 volts de (para 4-17, item No. 5).
		Rotate test set MC FREQ select switches 10MC and 1 MC from 2.0 me to 29.0 me in 1-mc steps. <i>Note.</i> As MC FREQ select switches are turned clockwise, mc shaft coupler advances 90° per 1-mc step.	Tray A1 mc shaft coupler should rotate and indicate 29 positions selected (para 4-17, item No. 6).
8	Disconnect AN/PSM-6 -----	Reset all switches and controls to settings listed in paragraphs 3-10 and 3-11.	Test set and tray A1 POWER indicators extinguish.

4-17. Common Module Tray A1, Trouble Isolation Chart

Item No.	Trouble symptom	Probable trouble	Checks and corrective measure
1	Test set POWER indicator does not illuminate.	a. Defective external 27-volt dc power supply. b. Improper seating of input power connector. c. Defective test set fuse----- d. Defective indicator light----- e. Defective POWER switch ----- f. Defective test set SERV SEL switch.	a. Higher category repair required. b. Tighten power connector. c. Replace fuse (para 4-26a). d. Replace indicator light (para 4-26b). e. Higher category repair required f. Higher category repair required
2	+27 ± 1 volts dc is not obtainable at DC/DC LOAD SELECT CONVERTER HI and LOW test connectors.	a. Defective DC/DC converter ----- b. Defective test set SERV SEL switch.	a. Higher category repair required. b. Higher category repair required.
3	Tray A1 POWER indicator does not illuminate with new lamp.	a. Broken or improperly seated connectors. b. Defective indicator ----- c. Defective POWER switch -----	a. Repair or replace as required. b. Check lamp by replacing it c. Higher category repair required.
4	Rotating RF AMPL AGC OFF-ON control does not vary voltage from 0 to 28 volts.	a. Broken or improperly seated connectors. b. Defective RF AMPL AGC OFF-ON control. c. Defective RF AMPL AGC OFF-ON switch quired.	a. Higher category repair required. b. Higher category repair required. c. Higher category repair required.
5	20 volts dc not obtainable at NOISE BLANKER NOISE BLANKER 20 VDC test connector.	Broken or improperly seated connectors.	Higher category repair required.
6	Me shaft coupler will not rotate or does not indicate one or all of 28 positions selected by test MC FREQ select switches.	Defective motor-----	Listen for motor operation; if motor operation cannot be heard, higher category repair required.

4-18. Common Module Tray A2, Trouble Localization Chart

The chart below specifies the performance required to be sure that tray A2 is operational.

Step No.	Operation of test equipment	Control setting and operation of equipment	Performance standard and reference
1	Remove tray A2 from storage case and secure it to test set.		
2	Insure that +27 vac primary power is supplied to connector on the test set.	Set test set switches and controls to settings listed in paragraph 3-10. Set tray A2 switches and controls to settings listed in paragraph 3-12.	

Step No.	Operation of test equipment	Control setting and operation of equipment	Performance standard and references
3		Set test set POWER switch to ON.	Test set POWER indicator illuminates.
4	Note. Allow 10-minute warmup period for test set frequency standard.	Rotate test set SERV SEL switch to SSB/NSK. Set tray A2 POWER switch to ON.	Tray A2 POWER indicator illuminates (para 4-19, item No. 1).
5	Connect AN/PSM-6 de test leads to RCVR IF. test connectors HI and LO.		30 \pm 2 volts dc (para 4-19, item No. 2).
6		Set RCVR IF TEST SELECTOR switch to 2. Rotate RCVR IF RF GAIN control from fully counterclockwise to fully clockwise	Dc voltage should vary from 0.35 to 2.5 volts dc (para 4-19, item No. 3).
7	Observe AN/PSM-6 dc voltage indication when test set RC-XMIT switch is set to XMIT.	Switch test set RC-XMIT switch from REC to XMIT, then to REC.	Dc voltage drops to 0 volt dc when REC-XMIT switch is set to XMIT (para 4-19, item No. 4).
8		Set RCVR IF TEST SELECTOR switch to 3. Rotate test set SERV SEL switch to CW. Rotate RCVR IF BFO TONE control from fully counterclockwise to fully clockwise.	+20 \pm 1 volts dc (BFO TONE control has no effect on voltage) (para 4-19, item No. 5).
9	Connect AN/USM-207 to test set IF OSCILLATOR TWO TONE OUT connector (use HI gain preamplifier on AN/USM-207). Refer to figure 4-1.	Set RCVR IF AGC SYNC switch to ON, and test set IF OSCILLATOR select switch to 1+2.	1.7615 mc \pm 100 cps (para 4-19, item No. 6).
10.		Set test set IF OSCILLATOR select switch to 1+3.	1.7525 mc \pm 100 cps (para 4-19, item No. 7).
11	Measure dc voltage at XMTR IF AND AUDIO test points HI and LO.		\pm 20 \pm 1 volts dc (para 4-19, item No. 8).
12		Set XMTR IF AND AUDIO TEST SELECTOR switch to 3. Set test set KEY switch to ON. Rotate XMTR IF AND AUDIO ALC APC PPC CONTROL POWER CONTROL from fully counterclockwise to fully clockwise.	Dc voltage should vary from minimum of 0 volt do to maximum of +20 volts dc (para 4-19, item No. 9).
13	Disconnect all test equipment.	Reset all switches and controls to positions listed in paragraphs 3-10 and 3-12.	Test set and tray A2 POWER indicator extinguish.

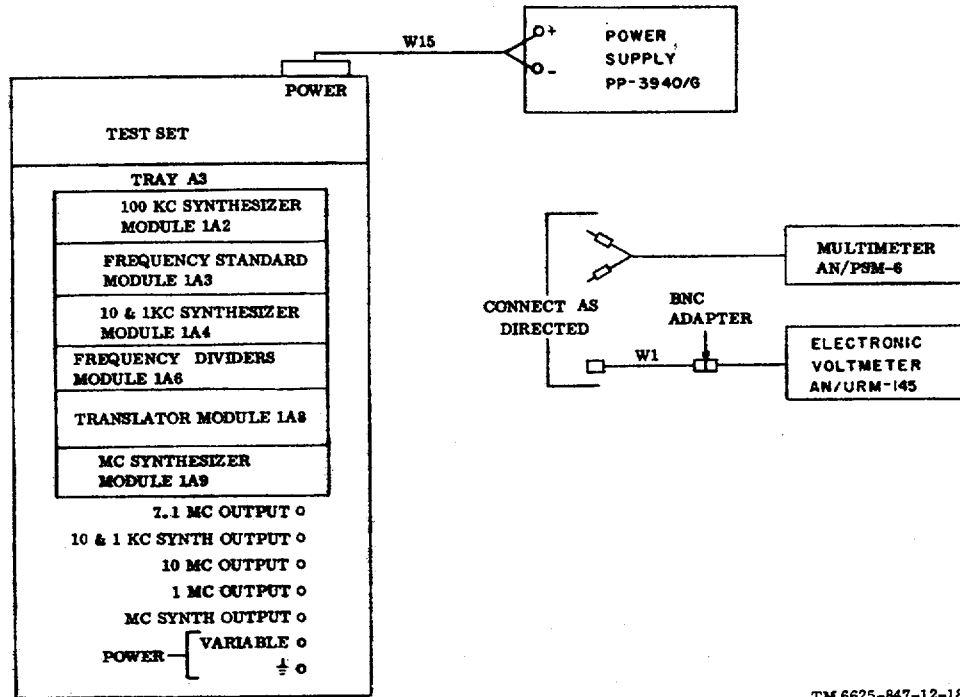

TM 6625-847-12-18

Figure 4-2. Synthesizer test tray A3, trouble localization test equipment.

4-19. Common Module Tray A2, Trouble Isolation Chart

Item No.	Trouble symptom	Probable trouble	Checks and corrective measure
	POWER indicator lamp will not illuminate	a. Defective external 27-volt dc power supply. b. Improper seating of input power connector. c. Defective test set fuse----- d. Defective indicator light----- e. Defective POWER switch ----- f. Defective test set SERV SEL	a. Higher category repair required. b. Tighten power connector. c. Replace fuse (para 4-26a). d. Replace indicator light (para 4-26b). e. Higher category repair required. f. Higher category repair required.
2	When AN/PSM-6 dc tests leads are connected to RCVR IF test points HI and LO, voltage varies more or less than limits of 29 to 31 volts dc.	a. Improper seating of input power connector. b. Defective RCVR IF TEST SELECTOR switch.	a. Tighten power connector. b. Higher category repair required.
3	When RCVR IF TEST SELECTOR switch is placed at 2, and RCVR IF GAIN control is rotated from fully counter-clockwise to clockwise, voltage varies more or less than limits of 0.35 to 2.5 volts dc.	a. Improper seating of input power connector. b. Defective RCVR IF TEST SELECTOR switch. c. Defective RCVR IF RF GAIN control.	a. Tighten power connector. b. Higher category repair required c. Higher category repair required.

Item No.	Trouble symptom	Probable trouble	Checks and corrective measures
4	With AN/PSM-6 connected as described in items 2 and 3 above and test set REC-XMIT switch is set to XMIT, voltage is above 0 volt dc .	<ul style="list-style-type: none"> a. Improper seating of input power connector. b. Defective RCVR IF TEST SELECTOR switch.. c. Defective REC-XMIT switch. 	<ul style="list-style-type: none"> a. Tighten power connector. b. Higher category repair required. c. Higher category repair required.
5	With AN/PSM-6 connected as described in item 4 above, RCVR IF TEST SELECTOR switch set to 3, test set SERV SEL switch set to CW, and RCVR IF BFO TONE control rotated fully counter-clockwise to fully clockwise, voltage on AN/PSM- varies more or less than limits of 19 to 21 volts dc.	<ul style="list-style-type: none"> a. Improper seating of input power connector. b. Defective RCVR IF TEST SELECTOR switch. c. Defective test set SERV SEL switch. 	<ul style="list-style-type: none"> a. Tighten the power connector. b. Higher category repair required. c. Higher category repair required.
6	With AN/USM-207 connected to test set IF OSCILLATOR TWO TONE OUT connector, RCVR IF AGC SYNC switch to on and test set IF OSCILLATOR select switch to 1+2; frequency observed on AN/USM-207 varies more or less than limits of 1.7514 to 1.7516 mc.	<ul style="list-style-type: none"> a. Improper seating of input power connector. b. Defective RCVR IF TEST SELECTOR switch. c. Defective test set SERV SEL switch. 	<ul style="list-style-type: none"> a. Tighten power connector. b. Higher category repair required. c. Higher category repair required.
7	With AN/USM-207 connected to test set IF OSCILLATOR TWO TONE OUT connector, set RCVR IF AGC SYNC switch to on and test set IF OSCILLATOR select switch to 1 +3; frequency observed on AN/USM-207 varies more or less than limits of 1.7524 to 1.7526 mc.	<ul style="list-style-type: none"> a. Improper seating of input power connector. b. Defective RCVR IF TEST SELECTOR switch. c. Defective test set SERV SEL switch. 	<ul style="list-style-type: none"> a. Tighten power connector. b. Higher category repair required. c. Higher category repair required.
8	When AN/PSM-6 de test leads are connected to XMIT IF AND AUDIO test points LO and HI, voltage varies more or less than limits of 10 to 21 volts de.	<ul style="list-style-type: none"> a. Improper seating of input power connector. b. Defective XMIT IF AND AUDIO TEST SELECTOR switch. c. Defective external 27-volt de power supply. d. Improper seating of XMIT IF AND AUDIO connector. 	<ul style="list-style-type: none"> a. Tighten power connector. b. Higher category repair required. c. Higher category repair required. d. Higher category repair required.

Item No.	Trouble symptom	Probable trouble	Checks and corrective measure
9	With AN/PSM-6 dc test leads connected to XMIT IF AND AUDIO test points LO and HI, and XMIT IF AND AUDIO TEST SELECTOR switch set to 3, voltage varies more or less than limits of 0 to 20 volts dc when XMIT IF AND AUDIO ALC APC PPC CONTROL POWER CONTROL is rotated from fully counterclockwise to fully clockwise.	<p>a. Improper seating of input power connector.</p> <p>b. Defective XMIT IF AND AUDIO TEST SELECTOR switch.</p> <p>c. Defective external 28-volt dc power supply.</p>	<p>a. Tighten power connector.</p> <p>b. Higher category repair required.</p> <p>c. Higher category repair required.</p>

4-20. Synthesizer Test Tray A3, Trouble Localization Chart

The chart below specifies the performance required to be sure that tray A3 is operational.

Step No.	Operation of test equipment	Control setting and operation of equipment	Performance standard and references
1	<p>Insure that +27-volt dc primary power is supplied to the test set POWER connector.</p> <p>Remove tray A3 from storage case and install in test set.</p> <p>Connect test equipment as indicated in figure 4-2, and apply operating power to test equipment. Secure the following RT-662/GRC modules, and install them in appropriate connectors on tray A3 (observe coupled alignments):</p> <p>a. 100 kc synthesizer Module RT-662/GRC.</p>	Set test set switches and controls to settings listed in paragraph 3-10.	<p>Test set POWER indicator illuminates (para 421, item No. 1).</p> <p>Tray A3 POWER indicator illuminates (para 4-21, item No. 2).</p> <p>Tray A3 MC SYNTH module coupler is adjusted to a new setting each time MC FREQ select switches 10MC and 1MC are adjusted (para 4-21, item No. 3).</p> <p>Tray A3 POWER indicator extinguishes.</p>
2			
3		Set tray A3 switches and controls to settings listed in paragraph 3-13.	
4		Set test set POWER switch to ON, and SERV SEL switch to STBY.	
5		Set tray A3 POWER switch to ON.	
6		Rotate test set MC FREQ select switches 10MC and 1MC from 2 me to 29 me in 1-mc steps. Observe tray A3 MC SYNTH module coupler (moves 12.8° per MC).	
7		Set tray A3 POWER switch to OFF, and test set SERV SEL switch to OFF.	
8			

Step No.	Operation of test equipment	Control setting and operation of equipment	Performance standard and references
9	<p>b. Frequency standard Module 1A3, RT-662/GRC.</p> <p>c. 10 and 1 kc synthesizer Module 1A4, RT-622/GRC.</p> <p>d. Frequency divider Module 1A6, RT-662/GRC.</p> <p>e. Translator Module 1A8, RT-662/GRC.</p> <p>f. Mc synthesizer Module 1A9, RT-/GRC.</p>		
10		<p>Set test set SERV SEL switch to STBY, and tray AS POWER switch to ON.</p> <p>If operating from a cold start, allow 15-minute warmup time for equipment stability. If equipment has been warmed up within the last hour, 5-minute warmup time is sufficient.</p>	<p>Tray A3 POWER indicator illuminates.</p>
11	<p>Connect AM/PSM-across tray AS POWER INPUTS VAR test connector and POWER INPUTS (ground) test connector.</p>	<p>Adjust tray AS POWER ADJ control from fully counterclockwise to fully clockwise.</p>	<p>AN/PSM-indicates voltage varying from minimum 0 volt dc to maximum +26 volts dc; set to +20 volts dc (para 4-21, item No. 4).</p>
12	<p>Disconnect AN/PSM-6.</p>		
13	<p>Connect AN/URM-145 to tray A2 10&1KC SYNTH OUTPUT 7.1 MC connector.</p> <p>Caution: Adjust AN/URM-145 to scale above 1 volt, and readjust accordingly to avoid damage to instrument.</p>	<p>Set 10&1KC SYNTH OUTPUT AMPL switch to ON, and adjust 10&1KC SYNTH OUTPUT VOLT ADJ control from fully counterclockwise to fully clockwise. Return 10&1KC SYNTH OUTPUT VOLT ADJ control from fully counterclockwise to fully clockwise. Return 10&1KC SYNTH OUTPUT VOLT ADJ control to mid-range.</p>	<p>Observe that output increases as adjustment is made clockwise (para 4-21, item No. 5).</p>
14	<p>Disconnect AN/URM-145 from 10&1KC SYNTH OUTPUT 7.1 MC connector.</p>		
15	<p>Connect AN/URM-145 to tray AS 10&1KC SYNTH OUTPUTS connector.</p> <p>Caution: Adjust AN/URM-145 to scale above 1 volt, and readjust accordingly to avoid damage to instrument.</p>	<p>Set tray A3 10&1KC SYNTH SYNTH OUTPUTS AMPL switch to ON, and adjust 10&1KC SYNTH SYNTH OUTPUTS VOLT ADJ control from fully counterclockwise to fully clockwise. Return 10&1KC SYNTH SYNTH OUTPUTS VOLT ADJ control to midrange.</p>	<p>Observe that the output increases as the adjustment is made clockwise (para 4-21, item No. 6).</p>
16	<p>Disconnect AN/URM-145 from 10&1KC SYNTH SYNTH OUTPUTS connector.</p>		

Step No.	Operation of test equipment	Control setting and operation of equipment	Performance standard and reference
17	Connect AN/URM-145 to tray A3 MC SYNTH OUTPUT MC SYNTH connector. Caution: Adjust AN/URM-145 to scale above 1 volt, and readjust accordingly to avoid damage to instrument.	Set tray A3 MC SYNTH OUTPUT AMPL switch to ON, and adjust MC SYNTH OUTPUT VOLT ADJ control from fully counterclockwise to fully clockwise. Return MC SYNTH OUTPUT VOLT ADJ control as to midrange.	Observe that output increases as adjustment is made clockwise (para 4-21, item No. 7).
18	Disconnect AN/URM-145.		
19		Reset all switches and controls to settings listed in paragraphs 3-10 and 3-13.	Test set and tray A3 POWER indicators extinguish
20	Remove RT-62/GRC modules (1A2, 1A3, 1A4, 1A8, and 1A9) from tray A3 and return them to proper storage place.	Remove tray A3 from test set and return to case 2.	

4-21. Synthesizer Test Tray A3, Trouble Isolation Chart

Item No.	Trouble symptom	Probable trouble	Checks and corrective measure
1	POWER indicator lamp will not illuminate.	a. Defective external 27-volt dc power supply. b. Improper seating of input power connector. c. Defective fuse----- d. Defective lamp-----	a. Higher category repair required. b. Tighten power connector. c. Replace fuse (para 4-26a). d. Replace indicator lamp (para 4-26b). e. Higher category repair required.
2	Tray A3 POWER indicator lamp will not illuminate.	a. Improper seating of input power connector. b. Defective test set fuse ----- c. Defective indicator lamp-----	a. Tighten power connector. b. Replace fuse (para 4-26a). c. Replace indicator lamp (para 4-26b).
3	When test set MC FREQ select switches 10MC and 1MC are rotated in 1-mc steps, module coupler does not adjust to new setting.	a. Improper seating of input power connector. b. Defective motor positioner -----	a. Tighten power connector. b. Higher category repair required.
4	With AN/PSM-6 connected across POWER INPUTS (ground) test connectors, adjust POWER ADJ control fully counterclockwise to fully clockwise; voltage varies more or less than limits of 0 to +26 volts dc	a. Improper seating of input power connector. b. Defective POWER switch -----	a. Tighten power connector. b. Higher category repair required.
5	With AN/URM-1465 connected to 10&1KC SYNTH OUTPUT 7.1 MC connector, indication	Improper seating of power connector.	Tighten power connector.

Item No.	Trouble symptom	Probable trouble	Checks and corrective measure
6	does not increase when 10&1KC SYNTH OUTPUT VOLT ADJ control is adjusted clockwise With AN/URM-145 connected to 10&1KC SYNTH SYNTH OUTPUTS '10&1KC connector, indication does not increase when 10&1KC SYNTH SYNTH OUTPUTS VOLT ADJ control is adjusted clockwise.	a. Improper seating of power connector. b. Defective VOLT ADJ control.	a. Tighten power connector. b. Higher category repair required.
7	With AN/URM-145 connected to MC SYNTH1 OUTPUT MC SYNTH connector, indication does not increase when MC SYNTH OUTPUT VOLT ADJ control is adjusted clockwise	a. Improper seating of power connector. b. Defective MC SYNTH OUTPUT VOLT ADJ control.	a. Tighten power connector. b. Higher category repair required.

4-22. Converter and Control Tray A4, Trouble Localization Chart

The chart below specifies the performance required to be sure that tray A4 is operational.

step No.	Operation of test equipment	Control setting and operation of equipment	Performance standard and references
1	Note. AN/PSM- is the only test equipment required for the following test. Remove tray A4 from storage case and secure to test set.		
2	Insure that +27-volt de primary power is supplied to test set POWER connector.	Set test set switches and controls to setting listed in paragraph 3-10. Set tray A4 switches and controls to settings listed in paragraph 3-14.	Para 4-23, item No. 1.
3		Set test set POWER switch to ON, and rotate SERV SEL switch to STBY. Set tray A4 POWER switch to ON.	Test set and tray A4 POWER indicators illuminate (para 4-23, item No. 1).
4	Connect AN/PSM-6 to test set DC VOLTAGE +20 test connector.	Adjust test set DC VOLTAGE +20 control to obtain an AN/PSM-6 20-volt dc indication.	
5		Press CONTROL TEST indicators A1 through A5, B1 through B5, and C1 through C5.	Each indicator should light when pressed (para 4-23, item No. 2).
6	Connect AN/PSM- d leads across PA METER TEST ANTENNA LOAD/TUNE test point and ground.	Rotate PA METER TEST ANTENNA LOAD/TUNE control from fully counterclockwise to fully clockwise.	Voltage should vary from -4 volts de to +3.6 volts de (para 4-23, item No. 3).
7	Connect AN/PSM- de test leads across PA METER TEST ALC METER test point and ground.	Rotate PA METER TEST ALC METER control from fully counterclockwise to fully clockwise.	Voltage should vary from 0 volt dc to +1.7 volts de (para 4-23, item No. 4).

step No.	Operation of test equipment	Control setting and operation of equipment	Performance standard and reference
8	Connect AN/PSM-6 dc test leads across PA METER TEST GRID DRIVE test point and ground.	Rotate PA METER TEST GRID DRIVE control from fully counterclockwise to fully clockwise.	Voltage should vary from 0 volt dc to 22 volts dc (para 4-23, item No. 5).
9	Connect AN/PSM-6 dc. test leads across INPUT CURRENT LO test point and ground.		+27 ± 1 volts dc
10		Press INPUT CURRENT test switch.	0 volt dc.
11	Disconnect AN/PSM-6	Reset all switches and controls to settings listed in paragraphs 3-10 and 3-14.	Test set and tray A4 POWER indicators extinguish.

4-23. Converter and Control Tray A4, Trouble Isolation Chart

Item No.	Trouble symptom	Probable trouble	Checks and corrective measure
1	POWER indicator will not illuminate	<ul style="list-style-type: none"> a. Improper seating of input power connector. b. Defective test set fuse----- c. Defective tray A4 fuse----- d. Defective indicator light----- e. Defective POWER switch ----- f. Defective 27-volt dc power supply. 	<ul style="list-style-type: none"> a. Tighten power connector. b. Replace fuse (para 4-26a). c. Replace fuse (para 4-26a). d. Replace indicator (para 4-26a). e. Higher category repair required. f. Higher category repair required.
2	CONTROL TEST indicators AI through AS, B1 through B5 and Ca through C5 will not light when press to test function of an indicator is pressed.	Defective indicator lights in lamp assemblies Z1 through Z16.	Replace indicator lamps 1 through 15 in lamp assemblies Z1 through Z15 as needed (para 4-26b).
3	When PA METER TEST ANTENNA LOAD/TUNE control is rotated from fully counterclockwise to fully clockwise, voltage varies more or less than limits of -4 to +3.6 volts dc.	<ul style="list-style-type: none"> a. Improper seating of input power connector. b. Defective PA METER TEST ANTENNA LOAD/TUNE control. 	<ul style="list-style-type: none"> a. Tighten power connector. b. Higher category repair required.
4	When PA METER TEST ALC METER control is rotated from fully counterclockwise to fully clockwise, voltage varies more or less than limits of 0 to +1.7 volts dc.	<ul style="list-style-type: none"> a. Improper seating of , put power connector. b. Defective PA METER TEST ALC METER control. 	<ul style="list-style-type: none"> a. Tighten power connector. b. Higher category repair required
6	When PA METER TEST GRID DRIVE control is rotated from fully counterclockwise to fully clockwise, voltage varies more or less than limits of 0 to 22 volts dc	<ul style="list-style-type: none"> a. Improper seating of input power connector. b. Defective PA METER TEST GRID METER control 	<ul style="list-style-type: none"> a. Tighten power connector. b. Higher category repair required.

Item No.	Trouble symptom	Probable trouble	Checks and corrective measures
6	When INPUT CURRENT switch is pressed, voltage is read across INPUT CURRENT LO test point and ground.	a. Improper seating of input power connector. b. Defective INPUT CURRENT switch. c. Defective fuse-----	a. Tighten power connector. b. Higher category repair required. c. Replace fuse (para 4-26a).

4-24. Driver, Discriminator, and Antenna Coupler Tray A5, Trouble Localization Chart

The chart below specifies the performance required to be sure that tray A4 is operational.

Step No.	Operation of test equipment	Control setting and operation of equipment	Performance standard and references
1	Note. The AN/PSM-4 is the only piece of test equipment required for following tests Remove tray AS from case 2 and secure it to test Bet.		
2	Insure +27-volt dc primary power is supplied to test set POWER connector.	Set test set switches and controls to setting listed in paragraph 3-10. Set tray A5 switches and controls to settings listed in paragraph 3-15.	Para 4-25, item No. 1.
3		Set test set POWER switch to ON, and rotate SERV SEL switch to STBY.	Test set POWER indicator illuminates.
4		Set tray A5 POWER switch to ON.	Tray A5 POWER, RELAY 1, and DRIVER 200 VDC indicators illuminate.
5		Rotate DRIVER BAND SEL control from 3.25 MC to 15.5 MC and 29.5 MC.	DRIVER 200 VDC indicator illuminates when DRIVER BAND SEL control is in a detent setting; extinguishes when rotating (para 4-25, item No. 2).
6	Connect AN/PCM-6 ac test leads to DRIVER test points HI and LO (located above RELAY RELAY CONTROL switch) .	Set DRIVER TEST SELECTOR switch to 1.	7 ± 0.5 volts ac (para 4-25, item No. 3).
7		Set DRIVER TEST SELECTOR switch to 2. Adjust test set DC VOLTAGE 200 control for +200-volt de indication on AN/PSM-6.	
8		Set DRIVER TEST SELECTOR switch to 4.	+27 ± 1 volts dc (Para 4-25, item No. 4).
9		Press RELAY 1 through 7 indicators.	Each RELAY indicator should light when pressed (para 4-25, item No. 5).
10	Disconnect AN/PSM-6 -----	Reset all switches and controls to positions listed in paragraphs 3-10 and 3-15.	Test set and tray A5 POWER indicators extinguish.

4-25. Driver, Discriminator, and Antenna Coupler Tray A5, Trouble Isolation Chart

Item No.	Trouble symptom	Probable trouble	Checks and corrective measures
1	POWER indicator will not illuminate. power connector.	a. Improper seating of input b. Defective test set fuse ----- c. Defective indicator light----- d. Defective POWER switch -----	a. Tighten power connector. b. Replace fuse (para 4-26a). c. Replace indicator light (para 4-26b). d. Higher category repair required.
2	DRIVER 200 indicator will not illuminate.	a. Microswitch defective ----- b. Defective 200-volt dc power supply. c. Defective indicator light----- d. Improper seating of input power connector. e. Improper seating of DISCRIMINATOR assembly connector, and discriminator assembly 2A4, AM-3349/GRC-106.	a. Higher category repair required. b. Higher category repair required. c. Replace indicator light (para 4-26b). d. Tighten power connector. e. Reset discriminator assembly; if this does not correct problem, check DISCRIMINATOR assembly connector for bent pins or broken wires. Higher category repair required.
3	DRIVER TEST SELECTOR switch set to 1, and AN/PSM-6 ac leads connected to DRIVER HI and LO test points (lower right side); voltage varies more or less than limits of 6.5 to 7.5 volts ac.	a. Defective DRIVER TEST SELECTOR switch b. Improper seating of input power connector. c. Defective 6.3-volt ac power supply.	a. Higher category repair required b. Tighten power connector. c. Higher category repair required.
4	DRIVER TEST SELECTOR switch set to 4; 27 volts dc is not present.	a. Defective DRIVER TEST SELECTOR switch b. Improper seating of input power connector. c. Defective test set fuse. d. Defective POWER switch----- e. Defective 27-volt dc power supply.	a. Higher category repair required. b. Tighten power connector. c. Replace fuse (par. 4-26a). d. Higher category repair required. e. Higher category repair required.
5	RELAY 1 through 7 indicators do not light when press to test function of indicators is press	Defective indicator lamp assemblies Z1 through Z7.	Replace RELAY indicators 1 through 7 in lamp assemblies Z1 through Z7 as needed (para 4-26b).

4-26. Replacement and Adjustments

a. *Replacement of Fuses.*

- (1) Press in on the fuse cap and turn it counterclockwise to unlock; remove the cap and the fuse.
- (2) Discard the old fuse and insert a new fuse of the same type and rating in the fuse cap. A spare fuse for the test

set is mounted in the spare fuseholder, directly below the main fuseholder. A spare fuse for tray A4 will be part of the running spare items list.

- (3) Replace the cap and the fuse in the fuseholder; tighten by pressing in and turning the cap clockwise.

b. Replacement of Indicator Lamps.

- (1) Unscrew the indicator lens (counterclockwise) and remove it from the lampholder.
- (2) Press in on the lamp bulb and turn it counterclockwise to unlock it.

- (3) Replace the defective lamp bulb with a new lamp bulb of the same type.

- (4) Replace the indicator lens.

c. Adjustment. No adjustment procedures are to be performed by organizational maintenance personnel.

CHAPTER 5
SHIPMENT, LIMITED STORAGE, AND DEMOLITION
TO PREVENT ENEMY USE

Section I. SHIPMENT AND LIMITED STORAGE

5-1. Disassembly of Equipment

Prepare the SM-442A/GRC for shipment and storage as follows:

- a. Disconnect all cabling, adapters, and dummy loads from the test set.
- b. Store cables, adapters, and dummy loads in the storage compartment in the front of cover of case 2.
- c. Check to see that trays A1 through A5 are mounted and secured in case 1.
- d. Close and secure the front covers on case 1 and case 2 with the attached fasteners.

5-2. Repacking for Shipment or Limited Storage

This section describes the method for preparing the SM-442A/GRC for reshipment. Package the units in the original containers. If the original containers are not available, use those of similar quantity and size.

5-3. Case 1

(fig. 2-1)

Package case 1 as follows:

- a. Place the four polystyrene corner pads in the

corrugated carton, arrange the pads so that they will receive the four corners of case 1 when it is placed in its carton.

- b. Place case 1 on the four polystyrene corner pads in the corrugated carton.
- c. Set one corner pad on each of the top corners of case 1.
- d. Place the polyethylene shroud over case 1.
- e. Place the taped corrugated carton into the plywood crate.

5-4. Case 2

(fig. 2-1)

Package case 2 as follows:

- a. Repeat the procedures given in paragraph 5-3a through f b. Place the top on the plywood crate and fasten it securely with No. 2 klimp fasteners.

5-5. Storage Conditions

- a. *Prolonged Storage.* Pack case 1 and case 2 in the plywood crate in which they were shipped.
- b. *Short storage.* Seal the self-contained storage cases and place them in an upright position.

Section II. DEMOLITION OF MATERIEL TO PREVENT ENEMY USE

5-6. Authority for Demolition

The demolition procedures given in paragraph 5-7 will be used to prevent the enemy from using or salvaging this equipment. Demolition of the equipment will be accomplished only upon the order of the commander.

5-7. Methods of Destruction

The tactical situation and the time available will determine the method to be used when destruction of equipment is ordered. In most cases, it is preferred to completely demolish some portions of the equipment rather than partially destroy all the equipment units.

- a. *Smash.* Smash the interior units of the SM-442A/GRC.

(1) Smash the connectors, the meters, the knobs, the dials, and the power supply.

Note. Heavy tools will effectively destroy the external parts mentioned in (1) above, but the remainder of the exposed surfaces of the equipment are constructed of steel plate; attempts to damage it by smashing will be useless.

(2) Remove the chassis from the cabinet. Smash as many of the exposed parts of the various chassis as possible.

- b. *Cut.* Cut the cabling, the cording, and the wiring. Cut the power cable and all the cords and the cables in a number of places.

Warning: Be extremely careful with explosives and incendiary devices. Use these items only when the need is urgent.

- c. *Burn.* Burn the technical manuals first. Burn as much of the equipment as is flammable. Pour gasoline on the cut cables and internal wiring and ignite them. Burn spare parts, or pour gasoline on the spare parts and ignite them. Complete the

destruction of the SM-442A/GRC.

d. Explode. USE explosives to complete demolition or to case destruction by other means. Power chargers, fragmentation grenades, or incendiary grenades may be used. Incendiary grenades usually are most effective if destruction of small parts and wiring is desired.

(1) Use a fragmentation grenade to destroy the interior of the test set. Unlatch the fasteners on the front cover of case 2; open the front cover. Release the six captive screws on the test set front panel. Pull the front panel forward and drop the grenade into the interior.

(2) Destroy case 1 by use of a fragmentation grenade as follow:

(a) Unlatch the fasteners on the front cover of case 1.

(b) Open the front cover and drop the grenade onto the top of the test tray in case 1.

(3) For quick destruction of the SM-442A/GRC, place an incendiary grenade on top of both of the unit. Get away from the units after the grenade is placed.

e. Dispose. Bury or scatter destroyed parts, or throw them into nearly important if a number of particularly important if a number of parts have not been completely destroyed.

Change 2 5-2

**APPENDIX A
REFERENCES**

Following is a list of references available to the operator and organizational repairman of Simulator, Radio Frequency SM-442A/GRC.

DA Pam 3104	Index of Technical Manuals, Technical Bulletins, Supply Manuals (Types 7, 8, and 9), Supply Bulletins, and Lubrication Orders.
DA Pam 310-7 SB 38-100	Modification Work Orders. Preservation, Packaging, and Packing Materials, Supplies, and Equipment Used by the Army.
TB SIG 291	Safety Measures to be observed When Installing and Using Whip Antennas, Field Type Masts, Antennas, and Metal Poles that are used with Communication, Radar, and Direction Finder Equipment.
TB 434118	Field Instructions for Painting and Preserving Electronics Command Equipment Including Camouflage Pattern Painting of Electrical Equipment shelters.
TM 43-0139	Painting Instructions for Field Use.
TM 114820-520-12	Operator's and Organizational Maintenance Manual Including Repair Parts and Special Tools Lists: Radio Sets AN/GRC-106 and AN/GRC-106A.
TM 38-750	The Army Maintenance Management System (TAMMS).
TM 740-90-1	Administrative Storage of Equipment.

Change 2 A-1

APPENDIX C MAINTENANCE ALLOCATION

Section I. INTRODUCTION

C-1. General

This appendix provides a summary of the maintenance operations for SM-442A/GRC. It authorizes categories of maintenance for specific maintenance functions on repairable items and components and the tools and equipment required to perform each function. This appendix may be used as an aid in planning maintenance operations.

C-2. Maintenance Function

Maintenance functions will be limited to and defined as follows:

a. Inspect. To determine the serviceability of an item by comparing its physical, mechanical, and/or electrical characteristics with established standards through examination.

b. Test. To verify serviceability and to detect incipient failure by measuring the mechanical or electrical characteristics of an item and comparing those characteristics with prescribed standards.

c. Service. Operations required periodically to keep an item in proper operating condition, i.e., to clean, preserve, drain, paint, or to replenish fuel/lubricants/hydraulic fluids or compressed air supplies.

d. Adjust. Maintain within prescribed limits by bringing into proper or exact position, or by setting the operating characteristics to the specified parameters.

e. Align. To adjust specified variable elements of an item to about optimum or desired performance.

f. Calibrate. To determine and cause corrections to be made or to be adjusted on instruments or test measuring and diagnostic equipment used in precision measurement. Consists of the comparison of two instruments, one of which is a certified standard of known accuracy, to detect and adjust any discrepancy in the accuracy of the instrument being compared.

g. Install. The act of emplacing, seating, or fixing into position an item, part, module (component or assembly) in a manner to allow the proper functioning of the equipment/system.

h. Replace. The act of substituting a serviceable like-type part, subassembly, model (component or assembly) for an unserviceable counterpart.

i. Repair. The application of maintenance services (inspect, test, service, adjust, align, calibrate, replace) or other maintenance actions (welding, grinding, riveting, straightening, facing, remachining, or resurfacing) to restore serviceability to an item by correcting specific damage, fault, malfunction, or failure in a part, subassembly, module/component/assembly, end item or system. This function does not include the trial and error replacement of running spare type items such as fuses, lamps, or electron tubes.

j. Overhaul. That periodic maintenance effort (service/action) necessary to restore an item to a completely serviceable/operational condition as prescribed by maintenance standards (e.g., DMWR) in appropriate technical publications. Overhaul is normally the highest degree of maintenance performed by the Army. Overhaul does not normally return an item to like-new condition.

k. Rebuild. Consists of those services/actions necessary for the restoration of unserviceable equipment to a like-new condition in accordance with original manufacturing standards. Rebuild is the highest degree of material maintenance applied to Army equipment. The rebuild operation includes the act of returning to zero those age measurements (hours, miles, etc) considered in classifying Army equipment/components.

C-3. Column Entries

a. Column 1, Group Number. Column 1 lists group numbers, the purpose of which is to identify components, assemblies, subassemblies and modules with the next higher assembly.

b. Column 2, Component/Assembly. Column 2 contains the noun names of components, assemblies, subassemblies, and modules for which maintenance is authorized.

c. Column 3, Maintenance Functions. Column 3 lists the functions to be performed on the item listed in column 2. When items are listed without maintenance functions, it is solely for purpose of having the group numbers in the MAC and RPSTL coincide.

d. Column 4, Maintenance Category. Column 4 specifies, by the listing of a "worktime" figure in the appropriate subcolumn(s), the lowest level of

maintenance authorized to perform the function listed in column 3. This figure represents the active time required to perform that maintenance function at the indicated category of maintenance. If the number or complexity of the tasks within the listed maintenance function vary at different maintenance categories, appropriate "worktime" figures will be shown for each category. The number of man-hours specified by the "worktime" figure represents the average time required to restore an item (assembly, subassembly, component, module, end item or system) to a serviceable condition under typical field operating conditions. This time includes preparation time, troubleshooting time and quality assurance/quality control time in addition to the time required to perform the specific tasks identified for the maintenance functions authorized in the maintenance allocation chart. Subcolumns of column 4 are as follows:

- C - Operator/Crew
- O - Organizational
- F - Direct Support
- H - General Support
- D- Depot

e. *Column 5, Tools and Equipment.* Column 5

specifies by code, those common tool sets (not individual tools) and special tools, test, and support equipment required to perform the designated function.

C-4. Tool and Test Equipment Requirements (Table 1)

a. *Tool or Test Equipment Reference Code.* The numbers in this column coincide with the numbers used in the tools and equipment column of the MAC. The numbers indicate the applicable tool or test equipment for the maintenance functions.

b. *Maintenance Category.* The codes in this column indicate the maintenance category allocated the tool or test equipment.

c. *Nomenclature.* This column lists the noun name and nomenclature of the tools and test equipment required to perform the maintenance functions.

d. *National/NATO Stock Number.* This column lists the National/NATO stock number of the specific tool or test equipment.

e. *Tool Number.* This column lists the manufacturer's part number of the tool followed by the Federal Supply Code for manufacturers (5-digit) in parentheses.

Change 2 C-2

**SECTION II. MAINTENANCE ALLOCATION CHART
FOR
SIMULATOR, RADIO FREQUENCY SM-442A/GRC**

(1) GROUP NUMBER	(2) COMPONENT ASSEMBLY	(3) MAINTENANCE FUNCTION	(4) MAINTENANCE LEVEL					(5) TOOLS AND EQUIPMENT
			C	O	F	H	D	
00	SIMULATOR, RF SM-442A/GRC	Inspect ¹	0.2					
		Inspect ²	0.5					18,19
		Test ³	0.4					1 thru 7
		Test				0.5		1 thru 14
		Service ¹	0.2					
		Service				0.5		18,19
		Adjust ⁴	0.4					
		Adjust				0.5		18,19
		Calibrate				0.5		1 thru 14
		Repair ⁵	0.2					15 thru 19
		Repair ⁶				1.0		
		Repair					3.0	15 thru 19
		Overhaul					4.0	1 thru 19
		Rebuild					10.0	1 thru 19
01	FRAME, STORAGE	Inspect ⁷	0.1					
		Inspect				0.3		18,19
		Test ³	0.2					1 thru 6
		Test				0.4		1,2,6,9,13
		Service ¹	0.2					
		Service				0.3		18,19
		Adjust ⁴	0.3					6,9,13,18,19
		Adjust				0.5		6,9,13,18,19
		Calibrate				0.5		1 thru 6,9,13
		Repair ⁵	0.2					
		Repair ⁶				0.8		18,19
		Repair					1.0	18,19
		Overhaul					2.0	1 thru 6,9,13, 18,19
		Rebuild					4.0	1 thru 6,9,13, 18,19
0101	TRAY A1 (COMMON MODULE TRAY)	Inspect ¹	0.1					
		Inspect				0.3		
		Test ³	0.2					1
		Test				0.4		1
		Service ¹	0.2					
		Service				0.4		18,19
		Adjust	0.2					
		Adjust				0.4		
		Calibrate				0.5		1
		Repair ⁵	0.1					
		Repair ⁶				1.0		18,19
		Repair					2.0	18,19
		Overhaul					3.0	1,18,19
		Rebuild					4.0	1,18,19
010101	GEAR DRIVE ASSEMBLY	Inspect ¹	0.2					
		Inspect				0.4		18,19
		Test ³	0.2					
		Test				0.5		
		Service ¹	0.2					
		Service					0.5	18,19
		Repair					1.0	18,19
		Overhaul					2.0	18,19
		Rebuild					4.0	18,19

See footnotes at end of chart.

**SECTION II MAINTENANCE ALLOCATION CHART
FOR
SIMULATOR, RADIO FREQUENCY SM-442A/GRC**

(1) GROUP NUMBER	(2) COMPONENT ASSEMBLY	(3) MAINTENANCE FUNCTION	(4) MAINTENANCE LEVEL					(5) TOOLS AND EQUIPMENT
			C	O	F	H	D	
0102	TRAY A2 (COMMON MODULE TRAY)	Inspect ¹	0.1					
		Inspect				0.3		18,19
		Test ³	0.2					1,3
		Test				0.4		1,2,6,9,13
		Service ¹	0.2					
		Service				0.4		18,19
		Adjust	0.2					6,9,13,18
		Adjust				0.4		6,9,13,18
		Calibrate				0.5		2,6,9,13
		Repair ⁵	0.1					
		Repair				1.0		18,19
		Overhaul					2.0	1,2,6,9,13,18,19
		Rebuild					4.0	1,2,6,9,13,18,19
0103	TRAY A3 (SYNTHESIZER TEST TRAY)	Inspect ¹	0.1					
		Inspect				0.3		18,19
		Test ³	0.2					1,2
		Test				0.4		2,6,9,13
		Service ¹	0.2					
		Service				0.4		18,19
		Adjust ⁴	0.2					18,19
		Adjust				0.4		18,19
		Calibrate				0.5		1,2,6,9,13
		Repair ⁵	0.1					
		Repair ⁶				1.0		18,19
		Repair					2.0	18,19
		Overhaul					2.0	1,2,6,9,13,18,19
Rebuild					4.0	1,2,6,9,13,18,19		
010301	GEAR DRIVE ASSEMBLY	Inspect ¹	0.2					
		Inspect					0.4	18,19
		Test ³	0.2					
		Test					0.5	
		Service ¹	0.2					
		Service					0.5	18,19
		Repair					1.0	18,19
		Overhaul					2.0	18,19
Rebuild					4.0	18,19		
0104	TRAY A4 (CONVERTER AND CONTROL TRAY)	Inspect ¹	0.1					
		Inspect				0.3		18,19
		Test ³	0.2					1
		Test				0.4		1
		Service ¹	0.2					
		Service				0.4		18,19
		Adjust ⁴	0.2					18,19
		Adjust				0.4		18,19
		Calibrate				0.5		18,19
		Repair ⁵	0.1					
		Repair				1.0		18,19
		Overhaul					2.0	1,18,19
		Rebuild					4.0	1,18,19

See footnotes at end of chart.

**SECTION II MAINTENANCE ALLOCATION CHART
FOR
SIMULATOR, RADIO FREQUENCY SM-442A/GRC**

(1) GROUP NUMBER	(2) COMPONENT ASSEMBLY	(3) MAINTENANCE FUNCTION	(4) MAINTENANCE LEVEL					(5) TOOLS AND EQUIPMENT		
			C	O	F	H	D			
0105	TRAY A5 (DRIVER, DISCRIMINATOR, AND ANTENNA COUPLER TRAY)	Inspect1	0.2							
		Inspect				0.3		18,19		
		Test3	0.2					1		
		Test				0.4		1		
		Service1	0.2							
		Service				0.4		18,19		
		Calibrate				0.5		1		
		Repair5	0.1							
		Repair				1.0		18,19		
		Overhaul					2.0	1,18,19		
		Rebuild					4.0	1,18,19		
0106	10-XHZ SYNTHESIZER MODULE 1A2	Inspect1	0.2							
0107	FREQUENCY STANDARD MODULE 1A3	Inspect				0.3	18,19			
		Test3	0.2				1 thru 6			
		Test				0.5	1 thru 14			
0108	10-KHZ AND 1-HZ SYNTHESIZER MODULE 1A4	Service1	0.2							
0109	FREQUENCY DIVIDER MODULE 1A6	Service adjust				0.4	18,19			
0110	MC SYNTHESIZER 1A9 Align					1.0	18,19			
		Repair				1.0	18,19			
		Rebuild				4.0	18,19			
0111	TRANSLATOR MODULE 1A8	Repair				8.0	18,19			
		Rebuild								
0111	TRANSLATOR MODULE 1A8	Inspect1	0.2							
		Inspect				0.3				
		Test3	0.2							
		Test					1.0	1 thru 14		
		Service1	0.2							
		Service					0.4	18,19		
		Adjust					1.0	18,19		
		Align					1.0	18,19		
		Repair					6.0	18,19		
		Rebuild					8.5	18,19		
		02	TEST SET	Inspect1	0.3					
				Inspect				0.4		18,19
				Test3	0.3					1 thru 7
				Test				0.5		1 thru 14
Service1	0.3						0.5	18,19		
Service							0.5	18,19		
AdJust4	0.2									
Adjust						0.5		18,19		
Calibrate						0.5		1 thru 14		
Repair5	0.2									
Repair						1.0		18,19		
Overhaul					3.0	1 thru 19				
Rebuild					8.0	1 thru 19				
03	CABLE ASSEMBLIES W1 Through W25	Inspect	0.2							
		Test	0.5							
		Service	0.5							
		Repair				0.5				
		Overhaul					0.8			
		Rebuild					1.0			

- (1) Exterior only.
- (2) All inspections.
- (3) Operational performance tests only.
- (4) Only those adjustments which do not affect calibration.
- (5) By replacement of knobs and fuses.
- (6) All repair, except gear drive assemblies.
- (7) Exterior of cases and trays,

**TABLE 1. TOOL AND TEST EQUIPMENT REQUIREMENTS
FOR
SIMULATOR, RADIO FREQUENCY SM-442A/GRC**

TOOL OR TEST EQUIPMENT REF CODE	MAINTENANCE CATEGORY	NOMENCLATURE	NATIONAL/NATO STOCK NUMBER	TOOL NUMBER
1	C, H, D	MULTIMETER AN/URM-4105	6625-00-884-1758	
2	C, H, D	VOLTMETER, ELECTRONIC AN/URM-141	6625-00-973-3936	
3	C, H, D	FREQUENCY METER AN/US-207	6625-00-911-6368	
4	C, H, D	GENERATOR, SIGNAL AN/URM-127	6625-00-78R-5965	
5	C, H, D	OSCILLOSCOPE AN/URM-281A	6625-00-228-2201	
6	C, H, D	POWER SUPPLY PP-4763()/GRC	5820-00-937-7690	
7	C, H, D	MULTIMETER ME-26()/U	6625-00-360-2'93	
8	H, D	RADIO TEST SET AN/USM-306	6625-00-459-8568	
9	H, D	GENERATOR, SIGNAL AN/GRM-50	6625-II-86e-8351	
10	H, D	POWER SUPPLY PP-3940/G	6130-00-460-2148	
11	H, D	ANALYZER, SPECTRUM TS-723()/U	6625-00-668-9418	
12	H, D	ATTENUATOR CN-1128/U (HP-3550G)	5985-00-95'-1860	
13	H, D	TEST CABLES W1, W2, W3, W15, W22 AND W25 (P/O SM-442A, GRC)		
14	H, D	TEE CONNECTOR, BNC TYPE VG-274B/U 5935-00-926-7523		
15	H, D	EXTRACTION TOOL CANNON ELECTRIC CO		
16	H, D	INSERTION TOOL (WINCHESTER INC 107-1001)		
17	H, D	CRIMP AND EXTRACTION TOOL (WINCHESTER INC)		
18	H, D	TOOK KIT TK-100/G	5180-i0-605-017'	
19	H, D	TOOL KIT TK-105/G.	5180-00-610-81,	

**APPENDIX D
ORGANIZATIONAL MAINTENANCE REPAIR PARTS**

Section I. INTRODUCTION

D-1. General

This appendix contains a list of repair parts required for the performance of organizational maintenance for Simulator, Radiofrequency SM-442A/GRC.

Note, No special tools, test, or support equipment are required.

D-2. Explanation of Sections

This repair parts list is divided into sections.

a. Prescribed Load Allowance List (PLA), Section II. The PLA is a consolidated listing of repair parts allocated for initial stockage at organizational maintenance category. This is a mandatory minimum stockage allowance.

b. Repair Parts for Organizational Maintenance, Section III. Repairs parts authorized for , organizational maintenance is included in this section.

D-3. Explanation of Columns

An explanation of the columns in sections II and III is given below.

a. Source, Maintenance, and Recoverability Codes, Column 1, Section III.

(1) Source code, column 1a. The selection status and source for the listed item is noted here. Source codes and their explanations are as follows:

<i>Code</i>	<i>Explanation</i>
P - -	Applies to repair parts that are stocked in or supplied from the GSA/DSA, or Army supply system, and authorized for use at indicated maintenance categories.
A - -	Applies to assemblies that are not procured or stocked as such but are made up of two or more units, each of which

<i>Code</i>	<i>Explanation</i>
	carry individual stock numbers and descriptions and are procured and stocked and can be assembled by units at individual maintenance categories.

(2) *Maintenance code, column 1b.* The lowest category of maintenance authorized to install the listed item is noted here.

<i>Code</i>	<i>Explanation</i>
C	__ Operator/Crew
O	__ Organizational Maintenance

(3) *Recoverability code, column 1c.* The information in this column indicates whether unserviceable items should be returned for recovery or salvage. Recoverability code and its explanation is as follows:

Note. When no code is indicated in the recoverability column, the part will be considered expendable.

<i>Code</i>	<i>Explanation</i>
R - -	Applies to repair parts and assemblies which are economically repairable at DSU and GSU activities and normally are furnished by supply on an exchange basis.
	<i>b. Federal Stock Number, Column 1, Section II; Column 2, Section III.</i> The Federal stock number for the item is indicated in this column.
	<i>c. Description, Column 2, Section II; Column 3, Section III.</i> The Federal item name, a five digit manufacturer's code and a part number are included in this column.
	<i>d. Unit of Issue, Column 4, Section III.</i> The unit used as a basis if issue (e.g., ea, pr, ft, yd, etc) is indicated in this column.

e. *Quantity Incorporated in Unit Pack, Column 4, Section II; Column 5, Section III.* Not used.

f. *Quantity Incorporated in Unit, Column 6, Section III.* The quantity of repair parts in an assembly is given in this column.

g. *Maintenance Allowances, Column 3, Section II; Column 7, Section III.*

(1) The allowance columns are divided into subcolumns. Indicated in each subcolumn opposite each item is the total quantity of items authorized for the number of equipments supported. Items authorized for use as required but not for initial stockage are identified with an asterisk (*) in the allowance column.

(2) The quantitative allowances for organizational category of maintenance represents one initial prescribed load for a 15-day period for the number of equipments supported. Units and organizations authorized additional prescribed loads will multiply the number of prescribed loads authorized by the quantity of repair parts reflected in the appropriate density column to obtain the total quantity or repair parts authorized.

(3) Subsequent changes to organizational allowances will be limited as follows: No change in the range of items is authorized. If additional items are considered necessary, recommendation should be forwarded to Commanding General, U. S. Army Electronics Command, ATTN: AMSEL-MR-NMP-CR, Fort Monmouth, N. J., 07703, for exception or revision to the allowance list. Revisions to the range of items authorized will be made by the USA ECOM National Maintenance Point based upon engineering experience, demand data, or TAERS information.

h. *Illustration, Column 8, Section III.*

(1) Figure number, column 8a. Not used.

(2) Item or symbol number, column 8b. The callout number used to reference the item in the illustration appears in this column.

D-4. Location of Repair Parts

a. When the Federal stock number is unknown, follow the procedures given in (1) through (4) below.

(1) Locate the appropriate appendix of the repair parts list.

(2) If the item or symbol number is available, locate the item by scrutiny of column 8b of the repair parts list.

(3) If the item, symbol, and figure number are not known, check the description column (column 3) in the repair parts list to locate the part. The parts in the column are arranged in alphabetical order.

(4) Locate the applicable illustration in this manual and note the figure number and item number. Use the repair parts listing and locate the item number as noted on the illustration.

b. When the Federal stock number is known, use the repair part listing to find the repair part and the item number.

D-5. Federal Supply Codes

This paragraph list the Federal supply code and the associated manufacturer's name.

<i>Code</i>	<i>Manufacturer</i>
00141 -----	Pic Design Corp.
58189 -----	General Dynamics Corp, Electronics Div.
80058 -----	Joint Electronics Type Designation System
80063 -----	Army Electronics Command
81349 -----	Military Specifications
95712 -----	Dage Electric Co., Inc.
96906 -----	Military Standards

SECTION II. PRESCRIBED LOAD ALLOWANCE LIST

PRESCRIBED LOAD ALLOWANCE					
(1) FEDERAL STOCK NUMBER	(2) DESCRIPTION	(3) 15-DAY ORG MAINT. ALW			
		(A)	(B)	(C)	(D)
		1-5	6-20	21-50	51-100
5355-556-0145	KNOB: 96906; MS91528-1K2B	*	*	2	2
5355-582-3804	KNOB: 96906; MS91528-2P2B	*	*	*	2
5355-937-9335	KNOB: 96906; MS91528-OE1B	*	*	*	2
5920-243-3787	FUSE, CARTRIDGE: 81349; F03A250V10AS	2	2	3	6
5920-850-6092	FUSE, CARTRIDGE: 81349; F02B32V10AS	2	2	6	11
5935-965-4891	KNOB: 96906; MS91528-1C2B	*	*	2	2
6240-155-7836	LAMP INCANDESCENT: 96906; MS25237-327	2	2	4	8
6240-892-4420	LAMP, NEON: 96906; MS25252NE2D	*	*	*	2

SECTION III. ORGANIZATIONAL MAINTENANCE REPAIR PARTS LIST

SOURCE CD §	MAINT. CD §	REC. CODE §	REPAIR PARTS FOR ORGANIZATIONAL MAINTENANCE						UNIT OF ISSUE §	QTY INC IN UN PK §	QTY INC IN UNIT §	15 DAY ORG. MAINT. ALW. §				ILLUSTRATIONS §		
			(2) FEDERAL STOCK NUMBER	(3) DESCRIPTION								(A) 1-5	(B) 6-20	(C) 21-50	(D) 51-100	(A) FIGURE NUMBER	(B) ITEM OR SYMBOL NUMBER	
				MODEL	1	2	3	4										5
C	R	6625-937-4029							ea									
C		5935-201-2411							ea	2	*	*	*					
C		5935-837-9648							ea	1	*	*	*					
C		5935-901-8708							ea	1	*	*	*					
C		5935-832-9291							ea	1	*	*	*					
C		4931-546-6347							ea	1	*	*	*					
C		5920-850-6092							ea	2	2	2	6	11			A1A4F1, A1A4F2	
C		5920-243-3787							ea	2	2	2	3	6			A2A1F1	
0		5310-832-6186							ea	2	*	*	*	*			A1A1	
0		5935-965-4891							ea	17	*	*	2	2			A1A1, A1A2, A1A3, A1A4, A2A1	
0		5355-582-3804							ea	6	*	*	*	2			A1A1, A1A3, A1A5	
0		5355-556-0145							ea	18	*	*	2	2			A1A1, A1A3, A1A4, A1A5, A2A1	
0		5355-616-9604							ea	4	*	*	*	*			A1A2	
0		5355-937-9335							ea	5	*	*	*	2			A1A3	
0		5355-559-8943							ea	1	*	*	*	*			A2A1	
0		5355-937-9336							ea	4	*	*	*	*			A2A1	

SOURCE CD (1)	MAINT. CD (2)	REC. CODE (3)	REPAIR PARTS FOR ORGANIZATIONAL MAINTENANCE					UNIT OF ISSUE (4)	QTY INC IN UN PK (5)	QTY INC IN UNIT (6)	15 DAY ORG. MAINT. ALW. (7)				ILLUSTRATIONS (8)		
			FEDERAL STOCK NUMBER (2)	MODEL (3)							DESCRIPTION (3)	FIGURE NUMBER (A)	ITEM OR SYMBOL NUMBER (B)				
				1	2	3	4							5	(A)	(B)	
P	C	6240-892-155-7836							32								A1A1DS1 A1A2DS1 A1A3DS1 thru A1A3DS3 A1A4DS1 thru A1A4DS16 A1A5DS1, A1A5DS3 A1A5DS4, A1A5Z1 thru A1A5Z7 A2A1DS1 A1A5DS2
P	C	6240-892-4420						ea	1		*		2				

INDEX

	Paragraph	Page
Authority, demolition-----	5-6	5-1
Case 1:		
Packaging-----	5-3	5-1
Placement-----	2-4a	2-2
Case 2:		
Packaging-----	5-4	5-1
Placement-----	2-4b	2-2
Characteristics, technical-----	1-5	1-1
Checking unpacked equipment-----	2-3	2-1
Cleaning-----	4-5	4-2
Common module tray A1:		
Controls, indicators, and connectors-----	3-3	3-5
Preliminary switch and control settings-----	3-11	3-22
Trouble isolation chart-----	4-17	4-8
Trouble localization chart-----	4-16	4-7
Common module tray A2:		
Controls, indicators, and connectors-----	3-4	3-8
Preliminary switch and control settings-----	3-12	3-22
Trouble isolation chart-----	4-19	4-10
Trouble localization chart-----	4-18	4-8
Components, list-----	1-6	1-2
Controls, indicators, and connectors:		
Common module tray A1-----	3-3	3-5
Common module tray A2-----	3-4	3-8
Converter and control tray A4-----	3-6	3-15
Driver, discriminator, and antenna coupler tray A5-----	3-7	3-18
Operator's-----	3-1	3-1
Synthesizer test tray A3 S-----	3-5	3-12
Test set-----	3-2	3-1
Converter and control tray A4:		
Controls, indicators, and connectors-----	3-6	8-15
Preliminary switch and control settings-----	3-14	3-22
Trouble isolation chart-----	4-23	4-16
Trouble localization chart-----	4-22	4-15
Demolition, authority-----	5-6	5-1
Description, equipment-----	1-7	1-2
Destruction, methods-----	5-7	5-1
Disassembly, equipment-----	5-1	5-1
Driver, discriminator, and antenna coupler tray AS:		
Controls, indicators, and connectors-----	3-7	3-18
Preliminary switch and control settings-----	3-15	3-23
Trouble isolation chart-----	4-25	4-18
Trouble localization chart-----	4-24	4-17
Equipment:		
Description-----	1-7	1-2
Disassembly-----	5-1	5-1
Manual improvements, reporting-----	1-3c	1-1

	Paragraph	Page
Forms and records -----	1-8	1-1
Fuse replacement -----	4-26a	4-18
General operational instructions -----	3-8	3-21
Index, publications -----	1-2	1-11
Indicator lamps, replacement -----	4-26b	4-18
Initial adjustment -----	2-5	2-2
Limited storage -----	5-2	5-1
List, components-----	1-6	1-2
Lubrication-----	4-12	4-3
Manual, scope -----	1-2	1-1
Materials required, operator's maintenance -----	4-2	4-1
Methods, destruction -----	5-7	5-1
Module test operation -----	3-18	3-3
Operation:		
Module test -----	3-18	3-23
System test -----	3-17	3-23
Operational instructions, general-----	3-8	3-21
Operator's:		
Controls, indicators, and connectors -----	3-1	3-1
Maintenance, materials required-----	4-2	4-1
Maintenance, scope -----	4-1	4-1
Preventive maintenance -----	4-3, 4-4	4-1
Organizational:		
Maintenance, scope -----	4-6	4-2
Preventive maintenance -----	4-8, 4-9	4-2, 4-3
Test equipment required -----	4-7	4-2
Placement, case 1 -----	2-4a	2-2
Placement, case 2-----	2-4b	2-2
Preliminary switch and control settings:		
Common module tray A1-----	3-11	3-22
Common module tray A2-----	3-12	3-22
Converter and control tray A4 -----	3-14	3-22
Driver, discriminator, and antenna coupler trap A5-----	3-15	3-23
Synthesizer test tray A3 -----	3-13	3-22
Test set -----	3-10	3-21
Preservation -----	1-1	4-3
Preventive maintenance:		
Operator's -----	4-3, 4-4	4-1
Organizational -----	4-8, 4-9, 4-10	4-2, 4-3
Procedure, starting -----	3-16	3-23
Procedure, stopping-----	3-19	3-23
Prolonged storage -----	5-5a	5-1
Publications, index -----	1-2	1-1
Records and forms -----	1-3	1-1
Repacking, shipment -----	5-2	5-1
Replacements -----	2-6	4-18
Report:		
Damaged equipment -----	1-3b	1-1
Equipment manual improvements-----	1-3c	1-1
Improper shipment-----	1-3b	1-1
Unsatisfactory equipment-----	1-3a	1-1
Scope:		
Manual -----	1-1	1-1

	Paragraph	Page
Operator's maintenance -----	4-1	4-1
Organizational maintenance -----	4-6	4-2
Shipping container chart-----	2-2	2-1
Short storage -----	5-5 <i>b</i>	5-1
Starting procedure-----	1-6	2-23
Stopping procedure -----	3-19	2-23
Storage conditions -----	5-6	5-1
Synthesizer test tray A3:		
Controls, indicators, and connectors -----	3-5	3-12
Preliminary switch and control settings-----	3-13	3-22
Trouble isolation chart -----	4-21	4-14
Trouble localization chart -----	4-20	4-12
System test operation -----	3-17	3-23
Technical characteristics -----	1-5	1-1
Test equipment required -----	4-7	4-2
Test set:		
Controls, indicators, and connectors -----	3-2	3-1
Placement-----	2-4 <i>a</i>	2-2
Preliminary switch and control settings-----	3-10	3-21
Trouble isolation chart -----	4-15	4-6
Trouble localization chart -----	4-44	4-4
Trouble isolation chart:		
Common module tray A1 -----	4-17	4-8
Common module tray A2-----	4-19	4-10
Converter arid control tray A4-----	4-23	4-16
Driver, discriminator, and antenna couples tray A5 -----	4-25	4-18
Synthesizer test tray A3 -----	4-21	4-14
Test set -----	4-15	4-6
Trouble localization chart:		
Common module tray A1-----	4-16	4-7
Common module tray A2 -----	4-18	4-8
Converter and control tray A4 -----	4-22	4-15
Driver, discriminator, and antenna coupler tray A5 -----	4-24	4-17
Synthesizer test tray A3 -----	4-20	4-12
Test set -----	4-14	4-4
Troubleshooting, general -----	4-13	4-3
Unpacked equipment, checking -----	2-3	2-1
Unpacking -----	2-1	2-1

By Order of the Secretary of the Army:

HAROLD K. JOHNSON,
General, United States Army,
Chief of Staff.

Official:

KENNETH G. WICKHAM,
Major General, United States Army,
The Adjutant General.

Distribution:

Active Army.:

CONGA (1)	TOAD (14)
Dir./Trains (1)	LEAD (7)
CofEngrs (1)	NAAD (3)
TSG (1)	SVAD (3)
CofEngrs (1)	ATAD (10)
OCC,-E (2)	Svc Colleges (1)
USAMB (10)	1st Cav Div (7)
USAARENBD (2)	GENDEP (1)
USCONARC (2)	Sig Sec GENDEP (4)
USAMC (2)	Sig Dep (6)
USAMICOM (2)	USACRREL (2)
USAECOM (2)	Fort Huachuca (5)
ARADCOM (2)	WSMR (2)
ARADCOM Rgn (1)	Fort Carson (7)
OS Maj Comd (2)	USAERDAA (2)
USACDEC (10)	USAERDAW (2)
USASTRATCOM (2)	MAAG (2)
USAESC (70)	USARMIS (2)
Armies (1)	Units org under fol TOE:
Sig FLDMS (2)	(1 copy each)
USASESS (26)	11-155
USASA (2)	11-157
USACDCCEA (1)	11-158
USACDCCEA Pt Huachuca (1)	11487
Army Depots (1) except	11-592
LBAD (14)	11-97
SAAD (30)	29-134

NG: None.

USAR :None.

For explanation of abbreviations used, see AR 320-50.

RECOMMENDED CHANGES TO EQUIPMENT TECHNICAL PUBLICATIONS



THEN... JOT DOWN THE DOPE ABOUT IT ON THIS FORM, CAREFULLY TEAR IT OUT, FOLD IT AND DROP IT IN THE MAIL!

SOMETHING WRONG WITH THIS PUBLICATION?

FROM: (PRINT YOUR UNIT'S COMPLETE ADDRESS)

DATE SENT

PUBLICATION NUMBER

PUBLICATION DATE

PUBLICATION TITLE

BE EXACT... PIN-POINT WHERE IT IS

PAGE NO.

PARA-GRAPH

FIGURE NO.

TABLE NO.

IN THIS SPACE TELL WHAT IS WRONG AND WHAT SHOULD BE DONE ABOUT IT:

TEAR ALONG PERFORATED LINE

PRINTED NAME, GRADE OR TITLE, AND TELEPHONE NUMBER

SIGN HERE:

DA FORM 2028-2 JUL 79

PREVIOUS EDITIONS ARE OBSOLETE.

P.S.—IF YOUR OUTFIT WANTS TO KNOW ABOUT YOUR RECOMMENDATION MAKE A CARBON COPY OF THIS AND GIVE IT TO YOUR HEADQUARTERS.

